



Bulletin VX05



VANEAXIAL FANS

Models: VXD, VXB
Direct Drive and Belt Drive

MOVING YOUR WAY

CERTIFIED RATINGS

AMCA Certification



PennBarry certifies that the Vaneaxial fans shown herein are licensed to bear the AMCA Seal. The ratings shown are based on tests and procedures performed in accordance with AMCA Publication 211 and comply with the requirements of the AMCA Certified Ratings Program.

UL Certification

Vaneaxial model VXD will carry the cUL mark for the following:



- UL705 Power Ventilators (ZACT, ZACT7):
File #E256857

Table of Contents

Introduction	1
General Information	2
Features and Benefits	3
Options and Accessories	4
VXD - Dimensional Data	5
VXD - Direct Drive Fan Data	6
VXB - Dimensional Data	15
VXB - Belt Drive Fan Data	17
Sample Specifications	28
Limited Warranty	29

Visit Our Web Site

Point your internet web browser to www.PennBarry.com for up-to-the-minute information including:

- On-line catalog
- List of nearest PennBarry representatives
- What's New
- HVAC "Hot Links"

FANSIZER®

Product Selection Software

FanSizer software allows you to select the best centrifugal or axial unit for your application. Input CFM and static pressure, and FanSizer will make the optimum selection. It allows you to complete job schedules which you can store, modify and print in seconds. Features include: on-line help, on-screen product drawings and dimensions, and complete text specifications. In addition, you can convert job schedules to ASCII code for use with other programs like word processing.

©2005 PennBarry™ All rights reserved.

Following publication of this catalog changes may have been made in standard equipment, options and the like that would not be included.

We reserve the right to make changes at any time, without notice, to models, specifications, options, availability, etc.

This bulletin illustrates the appearance of PennBarry products at the time of publication and we reserve the right to make changes in design and construction at anytime without notice. Your local sales representative is the best source for current information.

General Information

VXD/VXB - Vaneaxial Fans

The PennBarry **Vaneaxial** (VXD and VXB) product line is the perfect choice when high volume, compact size, superior quality and long lasting fans are needed. These AMCA licensed products are among the most efficient and quietest fans. PennBarry's direct drive Vaneaxial fans use industry-standard foot mounted motors, while most competitor's motors require special shafts and "C" face mounting. That fact makes our products some of the best on the market. In addition, if there is ever a need to replace the motor, these standard motors are readily available and less expensive. And, of course, all PennBarry fans are balanced to an industry-leading level. Simply stated, PennBarry's Vaneaxial products lead the industry in every category.

- Sizes 012 through 060
- Volumes exceeding 120,000 CFM
- Static pressure to 7" w.g.
- Operational tip speeds to 22,000 FPM
- Power requirements under 150 HP
- Mechanical efficiencies exceeding 85%
- Each unit dynamically balanced and factory tested prior to shipment
- Motor frame sizes available to 405T



Saves Valuable Space

The advent of smaller equipment rooms demands effective use of space. Vaneaxial fans provide the most compact air moving equipment available.

Reduces Construction Costs

The inherent lower weight and effective balance of vaneaxial fans permit considerable reduction in structural mounting requirements. Because the "vaneaxial package" is much smaller than corresponding centrifugal designs, installation costs are significantly reduced.

Reduces Design Costs

Vaneaxial fans have unlimited mounting possibilities in either horizontal and vertical positions and allow the designer more latitude in mechanical design. These fans require much less of the designer's time in design analysis and layout stages compared to centrifugal fans.

Meets Medium Pressure System Criteria

Since the air directed from vaneaxials is in a straight path, they develop:

- higher static pressures than other axial fans
- higher capacity in low pressure ranges
- lower sound levels than other axial types
- maximum efficiency over wide range
- maximum horsepower utilization over a wider operating range

Features and Benefits

Vaneaxial Fans - VXD/VXB

PennBarry's Vaneaxial fan housings are constructed of heavy-gauge, continuously welded steel with bolt holes in the inlet and outlet flanges for easy duct connection. Neither motor nor wheel protrude outside of the casing. A bolt-on straightening vane section is mounted on the discharge end of the fan housing.

Motors are standard NEMA-T frame, readily available in ODP, TEFC or EXP enclosures. All motors and electrical components comply with NEMA, UL and CSA guidelines.

The VXD and VXB propeller utilizes leading-edge airfoil technology with unique high strength airfoil blades and 319F cast aluminum spherical hubs. The propellers are constructed with industrial certified welds per AWS standards. The hub is secured

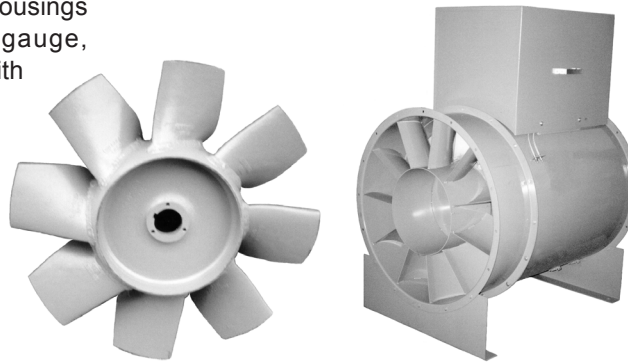

VXD and VXB Propeller

Belt Drive Unit with Optional Motor Cover

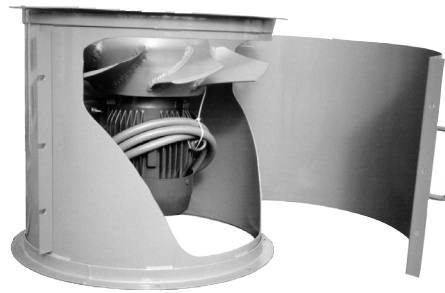

Direct Drive Unit With Optional Full Access Construction

to the fan or motor shaft using a key and taper lock bushing. They are dynamically balanced to quality grade G-6.3 using state of the art balancing equipment.

Direct drive models have a selective pitch variance between 12 and 30 degrees. All sizes have motor leads extended to the exterior of the fan casing.

Belt drive models offer continuous motor adjustment and belt tensioning. The power transmission components are isolated from airstream contaminants. The bearing and belt tube section is fully welded and has a removable end cover to allow access to the bearings and drive sheave. Extended lube lines are supplied for routine lubrication. Fan bearings are re-greasable and self-aligning, with a minimum L10 life of 40,000 hours.

Optional Construction

SwingOut Design

SwingOut design fans enable routine cleaning and maintenance operations to be performed without removing the fan from the system. This is accomplished by hinging the casing and allowing the serviceable components to "swingout" with the hinged section while the casing remains attached to the ductwork. By providing quick and easy access to all internal parts, including the motor, shaft, propeller and bearings, maintenance is greatly simplified and costly downtime is minimized. This design is available for vertical mounting.

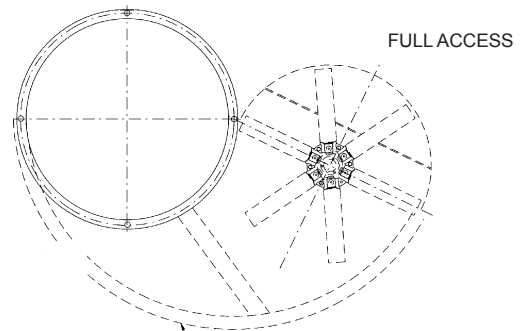
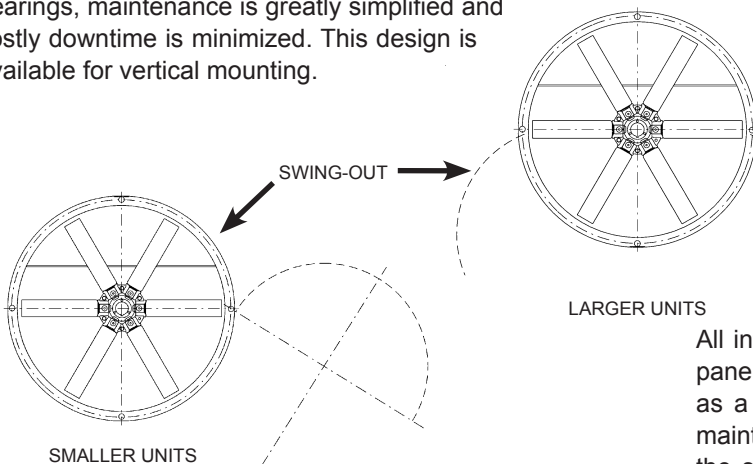

ADDITIONAL SUPPORT WILL BE ADDED AS REQUIRED

Full Access Design

Quick access to the fan interior is accomplished by a hinged outer section. This section opens 180° to provide plenty of room and freedom for most types of maintenance or service tasks.

All internal parts can be accessed via a removable access panel, enabling the wheel, shaft and bearings to be removed as a complete unit. This feature will save many hours of maintenance costs since the fan need not be removed from the system to keep it clean and operating efficiently. This design is available for horizontal ceiling hung and vertical mounting installations.

Options and Accessories

VXD/VXB - Vaneaxial Fans

Inlet/Outlet Cones

Inlet cones do not affect fan performance but are used to match the size of the inlet duct to the fan casing, when the latter is of a different size.

The outlet cone expands the casing to fit the usual duct size and converts the excess velocity to useful pressure.



Inlet/Outlet Cone

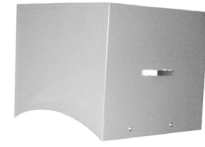

Motor Cover

Disconnect Switch

NEMA 1, 3R, 4X and 7/9 disconnect switches are offered. All disconnect switches are available mounted and unwired, mounted and wired, or shipped loose.



Disconnect Switch
(NEMA 3R)



Access Door

Access Door

Access doors are mounted on a fan to provide access to the fan interior for maintenance inspection.

Belt Guard

Belt guard with 1/2" expanded metal safety guard enclosing motor sheave and belts. A belt guard is not needed when a motor cover is ordered.



Belt Guard

Motor Cover

Motor covers, which are used for all weather protection, enclose the motor, motor sheave and belts.

Variable Inlet Vanes

Air volume control device mounted on the fan inlet. It is composed of several blades mounted radially on shafts. The position of the blades may be changed by rotating the shafts, and the area through which the air passes is increased or decreased as required. The variable inlet vane also acts to pre-spin the air as it enters the fan. The maximum velocity is 3000 FPM, the maximum pressure at block-off is 7" SP and the maximum temperature is 250°F. A manual lever is included.

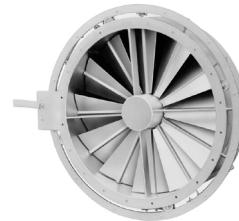

Variable Inlet Vane

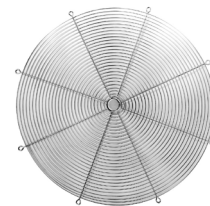

Inlet/Outlet Guard

Inlet/Outlet Guards

Guards are to be used with an open inlet or outlet. Inlet/outlet guards repel foreign matter and provide safety.

Inlet/Outlet Screens

Screens are 1/2" expanded metal welded to rings. Inlet/outlet screens can be bolted between the fan and inlet bell or duct without leakage.

Direct Drive Dimensional Data - VXD

Vaneaxial Fans

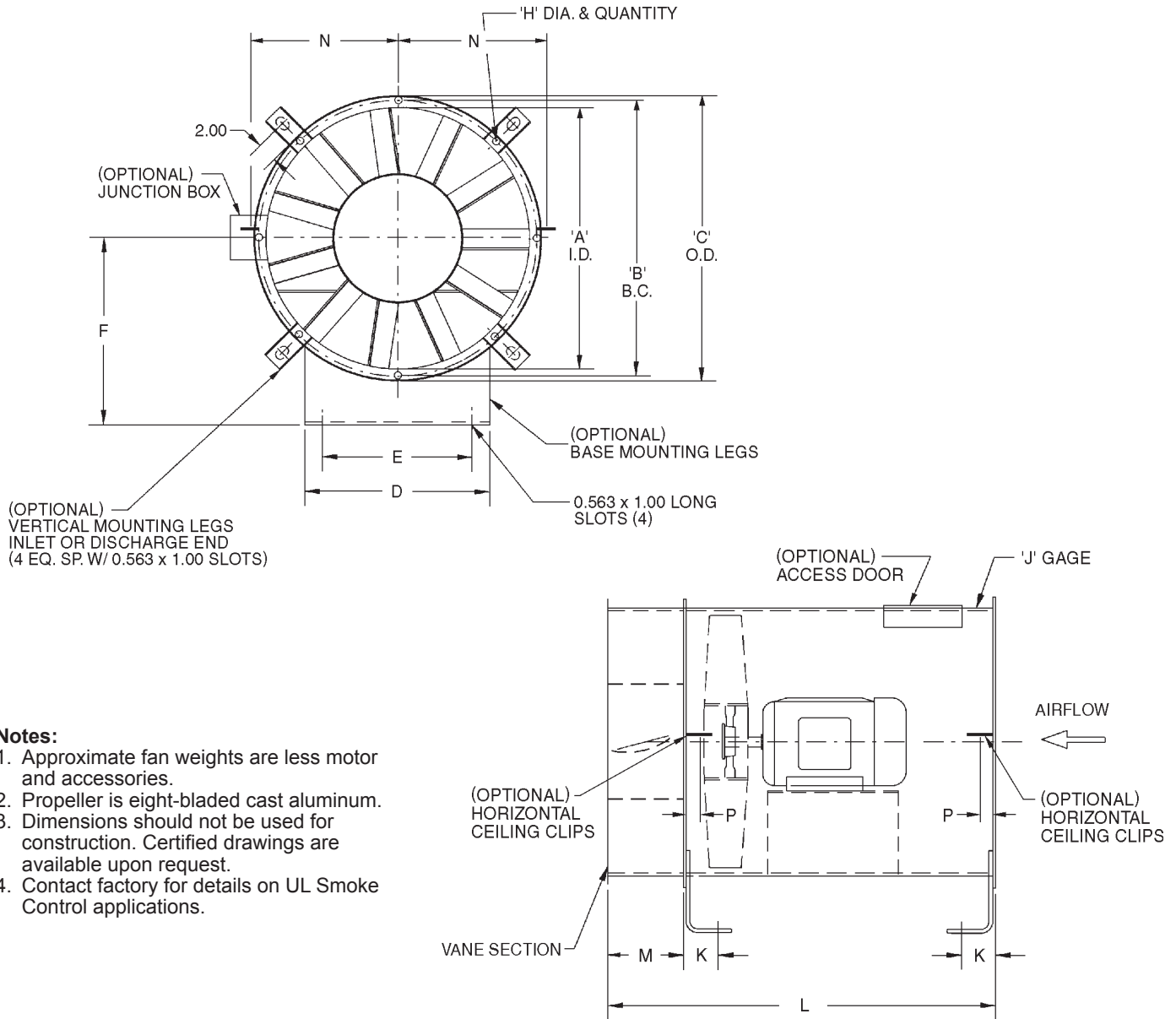

Notes:

1. Approximate fan weights are less motor and accessories.
2. Propeller is eight-bladed cast aluminum.
3. Dimensions should not be used for construction. Certified drawings are available upon request.
4. Contact factory for details on UL Smoke Control applications.

SIZE	A	B	C	D	E	F	H	J	K	L / MOTOR FRAME SIZE								M	N	P	UNIT WGT.	
										48-56	143-145	182-184	213-215	254-256	284-286	324-326	364-365					404-405
018	18.19	19.81	21.19	17.00	15.00	14.50	.438-8	12	1.71	23.63	23.63	29.63	29.63	—	—	—	—	—	5.63	10.16	3.10	130
021	21.22	22.97	24.22	20.00	18.00	16.00	.438-8	12	1.71	24.38	24.38	30.38	30.38	—	—	—	—	—	6.38	12.17	3.10	170
024	24.25	26.06	27.25	22.00	18.00	18.00	.438-8	12	1.71	31.38	31.38	31.38	31.38	37.38	—	—	—	—	7.38	13.69	3.10	250
030	30.31	32.19	33.31	29.00	25.00	21.50	.438-8	12	1.71	—	33.06	33.06	33.06	33.06	39.06	—	—	—	9.06	16.74	3.10	350
036	36.38	38.19	39.38	35.00	31.00	25.00	.438-16	10	1.73	—	35.13	35.13	35.13	41.13	47.13	47.13	—	—	11.13	19.75	3.13	600
042	42.44	44.81	46.44	40.00	36.00	29.00	.563-16	10	1.73	—	—	36.69	42.69	42.69	48.69	48.69	—	—	12.69	23.28	3.13	800
048	48.50	50.88	52.50	46.00	42.00	33.25	.563-16	10	1.73	—	—	38.50	44.50	44.50	50.50	50.50	50.50	—	14.50	26.31	3.13	1000
054	54.56	57.00	58.56	52.00	48.00	36.25	.563-16	7	1.78	—	—	—	—	52.31	52.31	58.31	58.31	64.31	16.31	29.38	3.18	1700
060	60.63	63.00	64.63	56.00	52.00	39.25	.563-16	7	1.78	—	—	—	—	54.31	54.31	60.31	60.31	66.31	18.31	32.38	3.18	2000

VXD - Direct Drive Fan Data

Vaneaxial Fan

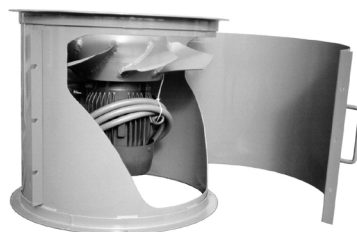

Direct Drive Unit
With Optional Full Access Construction

018

Wheel Diameter = 18 in.	Maximum RPM = 3450
Tip Speed, FPM = 4.71 x RPM	Bare Fan Weight = 130 lbs.
Inlet & Outlet Diameter (Area) = 18.19 in. (1.80 sq.ft.)	

RPM	PITCH	0" SP		1/4" SP		1/2" SP		3/4" SP		1" SP		1 1/4" SP	
		CFM	BHP	CFM	BHP	CFM	BHP	CFM	BHP	CFM	BHP	CFM	BHP
1150	12	1858	0.07	1489	0.10	785	0.12						
	18	2482	0.12	2098	0.16	974	0.17						
	24	2917	0.17	2513	0.21	1528	0.20						
	30	3521	0.27	3084	0.32	2408	0.33						
1750	12	2828	0.26	2602	0.30	2359	0.35	1993	0.39	1453	0.40		
	18	3777	0.42	3534	0.47	3281	0.55	2975	0.58	2386	0.61		
	24	4439	0.60	4180	0.66	3914	0.72	3606	0.77	3172	0.78		
	30	5358	0.93	5090	1.01	4795	1.09	4451	1.15	4024	1.16		
3450	12	5575	1.98	5457	2.06	5342	2.14	5229	2.23	5117	2.33	5002	2.43
	18	7446	3.21	7322	3.25	7199	3.35	7076	3.48	6953	3.63	6829	3.79
	24	8751	4.60	8624	4.67	8489	4.78	8357	4.91	8226	5.05	8095	5.18
	30	10563	7.16	10435	7.22	10297	7.38	10159	7.55	10018	7.72	9875	7.90

RPM	PITCH	1 1/2" SP		2" SP		2 1/2" SP		3" SP		3 1/2" SP		4" SP	
		CFM	BHP	CFM	BHP	CFM	BHP	CFM	BHP	CFM	BHP	CFM	BHP
3450	12	4883	2.53	4618	2.73	4292	2.92	3841	3.04	3262	3.07	2763	3.09
	18	6702	3.96	6437	4.28	6145	4.56	5802	4.73	5345	4.74	4191	4.48
	24	7962	5.32	7685	5.56	7385	5.76	7047	5.85	6646	5.96	6111	5.96
	30	9727	8.07	9417	8.38	9081	8.63	8709	8.81	8293	8.90	7818	8.93

- Notes:**
- 1) Performance shown is for Installation Type D: ducted inlet, ducted outlet.
 - 2) Performance ratings do not include the effects of appurtenances in the airstream.
 - 3) Power rating (BHP) does not include drive losses.

Direct Drive Fan Data - VXD

Vaneaxial Fan

021

Wheel Diameter = 21 in.	Maximum RPM = 3450
Tip Speed, FPM = 5.50 x RPM	Bare Fan Weight = 170 lbs.
Inlet & Outlet Diameter (Area) = 21.22 in. (2.45 sq.ft.)	

RPM	PITCH	0" SP		1/4" SP		1/2" SP		3/4" SP		1" SP		1 1/4" SP		1 1/2" SP	
		CFM	BHP	CFM	BHP	CFM	BHP	CFM	BHP	CFM	BHP	CFM	BHP	CFM	BHP
1150	12	2951	0.16	2544	0.21	1847	0.25								
	18	3941	0.26	3506	0.33	2935	0.38								
	24	4632	0.37	4170	0.43	3606	0.48								
	30	5591	0.57	5100	0.65	4478	0.71								
1750	12	4491	0.56	4225	0.63	3961	0.71	3652	0.79	3213	0.85	2565	0.86	2035	0.88
	18	5998	0.91	5714	0.98	5428	1.10	5121	1.23	4759	1.32	4239	1.33	2546	1.35
	24	7049	1.30	6747	1.38	6444	1.49	6124	1.59	5759	1.65	5302	1.68	4516	1.68
	30	8508	2.02	8199	2.12	7870	2.26	7511	2.39	7105	2.47	6631	2.51	6046	2.52
3450	12	8853	4.29	8716	4.42	8579	4.54	8446	4.67	8315	4.82	8184	4.97	8052	5.12
	18	11824	6.94	11680	6.99	11535	7.12	11391	7.29	11248	7.50	11105	7.73	10961	7.98
	24	13897	9.95	13753	10.04	13593	10.20	13438	10.40	13284	10.60	13131	10.81	12978	11.03

RPM	PITCH	2" SP		2 1/2" SP		3" SP		3 1/2" SP		4" SP		4 1/2" SP		5" SP		5 1/2" SP	
		CFM	BHP	CFM	BHP	CFM	BHP	CFM	BHP	CFM	BHP	CFM	BHP	CFM	BHP	CFM	BHP
3450	12	7777	5.44	7478	5.76	7138	6.07	6728	6.35	6202	6.55	5541	6.62	4881	6.63	4330	6.69
	18	10668	8.51	10363	9.04	10039	9.52	9686	9.92	9287	10.20	8804	10.29	8135	10.12	6111	9.84
	24	12669	11.46	12350	11.86	12014	12.21	11655	12.50	11261	12.71	10817	12.84	10293	12.89	9616	12.88

- Notes:**
- 1) Performance shown is for Installation Type D: ducted inlet, ducted outlet.
 - 2) Performance ratings do not include the effects of appurtenances in the airstream.
 - 3) Power rating (BHP) does not include drive losses.

VXD - Direct Drive Fan Data

Vaneaxial Fan

024

Wheel Diameter = 24 in.	Maximum RPM = 3450
Tip Speed, FPM = 6.28 x RPM	Bare Fan Weight = 250 lbs.
Inlet & Outlet Diameter (Area) = 24.25 in. (3.21 sq.ft.)	

RPM	PITCH	0" SP		1/4" SP		1/2" SP		3/4" SP		1" SP		1 1/4" SP		1 1/2" SP		2" SP	
		CFM	BHP	CFM	BHP	CFM	BHP	CFM	BHP	CFM	BHP	CFM	BHP	CFM	BHP	CFM	BHP
870	12	3874	0.16	3373	0.23	2465	0.26										
	18	4832	0.24	4248	0.32	3441	0.39										
	24	5690	0.33	5013	0.41	4060	0.49										
	30	6756	0.56	6055	0.62	3189	0.52										
1150	12	5120	0.37	4768	0.46	4341	0.55	3746	0.61								
	18	6387	0.56	5980	0.67	5484	0.77	4910	0.86								
	24	7521	0.76	7015	0.88	6481	0.98	5793	1.08	4862	1.17						
	30	8931	1.29	8434	1.38	7836	1.46	6973	1.52	5866	1.56						
1750	12	7792	1.31	7570	1.44	7333	1.58	7078	1.72	6799	1.87	6485	1.99	6122	2.09	5037	2.12
	18	9719	1.97	9472	2.15	9194	2.32	8888	2.49	8561	2.64	8216	2.78	7850	2.91	6973	3.16
	24	11445	2.68	11104	2.89	10779	3.06	10449	3.22	10100	3.36	9717	3.51	9284	3.65	8222	3.96
	30	13590	4.54	13274	4.67	12943	4.80	12590	4.94	12199	5.07	11750	5.18	11215	5.28	9857	5.41
3450	12	15361	10.04	15251	10.27	15140	10.51	15026	10.77	14911	11.03	14794	11.30	14674	11.58	14429	12.15
	18	19160	15.11	19041	15.47	18917	15.83	18789	16.18	18657	16.53	18522	16.88	18382	17.22	18091	17.88
	24	22563	20.52	22386	20.95	22211	21.38	22040	21.79	21872	22.17	21706	22.53	21541	22.88	21212	23.54

RPM	PITCH	2 1/2" SP		3" SP		3 1/2" SP		4" SP		4 1/2" SP		5" SP		5 1/2" SP		6" SP	
		CFM	BHP	CFM	BHP	CFM	BHP	CFM	BHP	CFM	BHP	CFM	BHP	CFM	BHP	CFM	BHP
1750	12	2757	2.33														
	18																
	24	6715	4.12														
	30	8316	5.50														
3450	12	14174	12.73	13908	13.31	13629	13.88	13335	14.43	13022	14.94	12688	15.39	12326	15.78	11929	16.09
	18	17785	18.53	17468	19.15	17139	19.74	16800	20.32	16542	20.88	16094	21.42	15726	21.95	15343	22.47

- Notes:** 1) Performance shown is for Installation Type D: ducted inlet, ducted outlet.
 2) Performance ratings do not include the effects of appurtenances in the airstream.

Direct Drive Fan Data - VXD

Vaneaxial Fan

030

Wheel Diameter = 30 in.	Maximum RPM = 1750
Tip Speed, FPM = 7.85 x RPM	Bare Fan Weight = 350 lbs.
Inlet & Outlet Diameter (Area) = 30.31 in. (5.01 sq.ft.)	

RPM	PITCH	0" SP		1/4" SP		1/2" SP		3/4" SP		1" SP	
		CFM	BHP	CFM	BHP	CFM	BHP	CFM	BHP	CFM	BHP
870	12	7566	0.49	6977	0.62	6238	0.75	5061	0.80		
	18	9437	0.74	8755	0.91	7915	1.05	6889	1.18		
	24	11113	1.00	10279	1.18	9364	1.32	8116	1.47		
	30	13196	1.70	12368	1.83	11323	1.95	9735	2.02		
1150	12	10001	1.13	9572	1.30	9097	1.49	8553	1.67	7894	1.80
	18	12474	1.71	11989	1.94	11422	2.15	10793	2.34	10110	2.51
	24	14689	2.32	14050	2.58	13426	2.78	12750	2.97	11959	3.16
	30	17443	3.93	16834	4.10	16175	4.27	15411	4.44	14448	4.57
1750	12	15219	4.00	14944	4.24	14659	4.50	14361	4.78	14049	5.07
	18	18982	6.02	18680	6.37	18353	6.72	18002	7.05	17628	7.37
	24	22354	8.17	21922	8.60	21508	8.97	21103	9.31	20694	9.62
	30	26543	13.84	26153	14.09	25747	14.36	25332	14.62	24900	14.89

RPM	PITCH	1 1/4" SP		1 1/2" SP		2" SP		2 1/2" SP		3" SP		3 1/2" SP	
		CFM	BHP	CFM	BHP	CFM	BHP	CFM	BHP	CFM	BHP	CFM	BHP
1150	12	6989	1.85	5069	1.83								
	18	9328	2.68	8096	2.81								
	24	10992	3.35	9829	3.53								
	30	13201	4.66	11811	4.73								
1750	12	13720	5.35	13370	5.63	12588	6.12	11632	6.45	10301	6.51	7490	6.50
	18	17235	7.68	16825	7.97	15963	8.52	15030	9.04	13943	9.54	12142	9.92
	24	20276	9.91	19839	10.20	18883	10.76	17762	11.34	16427	11.94	14868	12.47
	30	24443	15.15	23954	15.40	22833	15.86	21428	16.22	19708	16.46	17876	16.69

- Notes:**
- 1) Performance shown is for Installation Type D: ducted inlet, ducted outlet.
 - 2) Performance ratings do not include the effects of appurtenances in the airstream.
 - 3) Power rating (BHP) does not include drive losses.

VXD - Direct Drive Fan Data

Vaneaxial Fan

036

Wheel Diameter = 36 in.	Maximum RPM = 1750
Tip Speed, FPM = 9.42 x RPM	Bare Fan Weight = 600 lbs.
Inlet & Outlet Diameter (Area) = 36.375 in. (7.21 sq.ft.)	

RPM	PITCH	0" SP		1/4" SP		1/2" SP		3/4" SP		1" SP		1 1/4" SP	
		CFM	BHP	CFM	BHP	CFM	BHP	CFM	BHP	CFM	BHP	CFM	BHP
870	12	12759	1.04	11926	1.32	11001	1.59	9868	1.82	8101	1.97		
	18	15450	1.39	14565	1.81	13557	2.11	12377	2.34	10884	2.51		
	24	19405	2.53	18334	2.60	17204	2.87	15976	3.22	14509	3.50		
	30	21648	3.47	20558	3.67	19510	4.06	18160	4.45	16252	4.65		
1150	12	16865	2.40	16245	2.77	15597	3.15	14906	3.50	14148	3.84	13279	4.14
	18	20422	3.20	19771	3.82	19071	4.29	18316	4.70	17496	5.05	16594	5.34
	24	25650	5.84	24848	5.86	24024	6.07	23173	6.43	22289	6.86	21354	7.32
	30	28615	8.02	27795	8.18	27017	8.59	26213	9.11	25327	9.65	24288	10.17
1750	12	25664	8.47	25262	8.98	24852	9.58	24434	10.16	24008	10.74	23572	11.30
	18	31077	11.29	30658	12.44	30226	13.23	29780	13.98	29320	14.69	28844	15.36
	24	39033	20.57	38507	20.56	37980	20.59	37445	20.78	36904	21.12	36335	21.55
	30	43544	28.26	42990	28.29	42460	28.66	41946	29.19	41436	29.83	40923	30.55

RPM	PITCH	1 1/2" SP		2" SP		2 1/2" SP		3" SP		3 1/2" SP		4" SP		4 1/2" SP	
		CFM	BHP	CFM	BHP	CFM	BHP	CFM	BHP	CFM	BHP	CFM	BHP	CFM	BHP
1150	12	12210	4.39	8108	4.47										
	18	15578	5.59	12731	5.92										
	24	20337	7.75	17585	8.25										
	30	23007	10.55	19879	10.81										
1750	12	23123	11.84	22174	12.89	21131	13.87	19940	14.76	18494	15.52	16524	16.02	13316	15.89
	18	28353	15.99	27318	17.13	26203	18.13	24986	19.00	23629	19.73	22055	20.34	20050	20.78
	24	35798	22.08	34659	23.33	33475	24.71	32225	26.09	30872	27.37	29340	28.41	27415	29.03
	30	40400	31.32	39297	32.97	38069	34.62	36637	36.12	34910	37.24	32885	37.79	30786	38.02

- Notes:**
- 1) Performance shown is for Installation Type D: ducted inlet, ducted outlet.
 - 2) Performance ratings do not include the effects of appurtenances in the airstream.
 - 3) Power rating (BHP) does not include drive losses.

Direct Drive Fan Data - VXD

Vaneaxial Fan

042

Wheel Diameter = 42 in.	Maximum RPM = 1750
Tip Speed, FPM = 11.00 x RPM	Bare Fan Weight = 800 lbs.
Inlet & Outlet Diameter (Area) = 42.44 in. (9.82 sq.ft.)	

RPM	PITCH	0" SP		1/4" SP		1/2" SP		3/4" SP		1" SP		1 1/4" SP		1 1/2" SP		2" SP	
		CFM	BHP	CFM	BHP	CFM	BHP	CFM	BHP	CFM	BHP	CFM	BHP	CFM	BHP	CFM	BHP
695	12	16185	1.15	14960	1.50	13559	1.83	11676	2.10	7664	2.13						
	18	19599	1.53	18294	2.05	16772	2.41	14913	2.67	12122	2.82						
	24	24616	2.79	23046	2.90	21370	3.28	19481	3.70	16782	3.94						
	30	27461	3.83	25919	4.10	24285	4.61	22031	5.04	19010	5.16						
870	12	20260	2.25	19298	2.70	18274	3.14	17138	3.55	15797	3.91	14002	4.19	10761	4.23		
	18	24534	3.00	23519	3.71	22405	4.24	21171	4.68	19780	5.03	18144	5.31	15981	5.51		
	24	30814	5.46	29572	5.52	28285	5.85	26937	6.36	25496	6.91	23873	7.40	21789	7.70		
	30	34376	7.50	33125	7.75	31916	8.31	30594	8.96	28990	9.57	26892	9.97	24437	10.09		
1150	12	26781	5.20	26062	5.77	25320	6.38	24549	6.96	23740	7.53	22874	8.06	21930	8.57	19622	9.44
	18	32429	6.93	31677	7.97	30884	8.75	30047	9.46	29161	10.10	28221	10.67	27217	11.18	24947	12.02
	24	40732	12.62	39797	12.61	38848	12.82	37877	13.25	36882	13.83	35859	14.52	34800	15.24	32502	16.64
	30	45439	17.33	44471	17.50	43557	18.06	42648	18.78	41706	19.61	40698	20.48	39582	21.34	36808	22.73
1750	12	40753	18.31	40287	19.06	39811	20.02	39329	20.96	38841	21.89	38347	22.81	37843	23.71	36806	25.46
	18	49349	24.41	48862	26.40	48366	27.87	47858	29.21	47337	30.45	46804	31.59	46257	32.64	45122	34.52
	24	61983	44.46	61207	44.41	60521	44.46	59891	44.71	59291	45.11	58708	45.63	58132	46.23	56975	47.69

RPM	PITCH	2 1/2" SP		3" SP		3 1/2" SP		4" SP		4 1/2" SP		5" SP		5 1/2" SP		6" SP	
		CFM	BHP	CFM	BHP	CFM	BHP	CFM	BHP	CFM	BHP	CFM	BHP	CFM	BHP	CFM	BHP
1150	12	15763	9.86														
	18	22038	12.63														
	24	29678	17.66														
	30	33197	23.26														
1750	12	35717	27.14	34557	28.75	33302	30.27	31912	31.69	30324	32.96	28414	34.01	25919	34.68	22260	34.54
	18	43928	36.17	42668	37.69	41333	39.14	39908	40.59	38371	42.07	36684	43.54	34777	44.89	32497	45.72

- Notes:**
- 1) Performance shown is for Installation Type D: ducted inlet, ducted outlet.
 - 2) Performance ratings do not include the effects of appurtenances in the airstream.
 - 3) Power rating (BHP) does not include drive losses.

VXD - Direct Drive Fan Data

Vaneaxial Fan

048

Wheel Diameter = 48 in.	Maximum RPM = 1750
Tip Speed, FPM = 12.57 x RPM	Bare Fan Weight = 1000 lbs.
Inlet & Outlet Diameter (Area) = 48.50 in. (12.83 sq.ft.)	

RPM	PITCH	0" SP		1/4" SP		1/2" SP		3/4" SP		1" SP		1 1/4" SP		1 1/2" SP		2" SP	
		CFM	BHP	CFM	BHP	CFM	BHP	CFM	BHP	CFM	BHP	CFM	BHP	CFM	BHP	CFM	BHP
695	12	24159	2.24	22776	2.77	21270	3.29	19520	3.75	17201	4.12	12839	4.21				
	18	29255	2.98	27790	3.80	26148	4.40	24279	4.87	22061	5.23	19060	5.48				
	24	36745	5.43	34962	5.53	33097	6.01	31109	6.65	28883	7.26	25986	7.66				
	30	40991	7.46	39215	7.80	37455	8.51	35392	9.28	32624	9.86	29143	10.03				
870	12	30243	4.39	29150	5.04	28009	5.72	26796	6.36	25469	6.96	23957	7.51	22118	7.98	15225	8.20
	18	36622	5.85	35475	6.96	34244	7.80	32917	8.53	31480	9.17	29903	9.70	28135	10.16	23326	10.77
	24	45997	10.65	44583	10.68	43132	11.05	41635	11.69	40080	12.47	38441	13.29	36666	14.06	32016	15.05
	30	51313	14.63	49867	14.91	48496	15.65	47083	16.56	45533	17.55	43729	18.48	41517	19.20	36028	19.70
1150	12	39976	10.13	39158	10.96	38318	11.88	37459	12.78	36572	13.65	35649	14.49	34681	15.30	32548	16.82
	18	48408	13.50	47553	15.16	46664	16.37	45737	17.49	44771	18.53	43762	19.49	42707	20.37	40431	21.91
	24	60801	24.60	59733	24.67	58657	24.74	57562	25.20	56448	25.89	55313	26.76	54154	27.75	51743	29.90
	30	67827	33.79	66711	33.94	65652	34.64	64617	35.60	63575	36.72	62502	37.95	61377	39.24	58861	41.80
1750	12	60833	35.69	60303	36.71	59760	38.15	59213	39.58	58662	40.98	58105	42.37	57542	43.75	56394	46.44
	18	73664	47.59	73108	50.77	72546	53.02	71973	55.13	71390	57.11	70796	58.97	70191	60.71	68945	63.88

RPM	PITCH	2 1/2" SP		3" SP		3 1/2" SP		4" SP		4 1/2" SP		5" SP		5 1/2" SP		6" SP	
		CFM	BHP	CFM	BHP	CFM	BHP	CFM	BHP	CFM	BHP	CFM	BHP	CFM	BHP	CFM	BHP
1150	12	29971	18.15	26406	19.09	20041	18.93										
	18	37869	23.19	34842	24.20	30777	24.89										
	24	49141	32.01	46173	33.77	42265	34.75										
	30	55753	43.96	51830	45.12	47578	45.50										
1750	12	55212	49.05	53987	51.60	52707	54.06	51358	56.43	49924	58.71	48376	60.86	46679	62.87	44774	64.68
	18	67652	66.70	66308	69.25	64908	71.61	63449	73.84								

- Notes:**
- 1) Performance shown is for Installation Type D: ducted inlet, ducted outlet.
 - 2) Performance ratings do not include the effects of appurtenances in the airstream.
 - 3) Power rating (BHP) does not include drive losses.

Direct Drive Fan Data - VXD

Vaneaxial Fan

054

Wheel Diameter = 54 in.	Maximum RPM = 1150
Tip Speed, FPM = 14.14 x RPM	Bare Fan Weight = 1700 lbs.
Inlet & Outlet Diameter (Area) = 54.56 in. (16.24 sq.ft.)	

RPM	PITCH	0" SP		1/4" SP		1/2" SP		3/4" SP		1" SP		1 1/4" SP	
		CFM	BHP	CFM	BHP	CFM	BHP	CFM	BHP	CFM	BHP	CFM	BHP
695	12	34399	4.03	32853	4.78	31214	5.54	29417	6.24	27338	6.87	24690	7.40
	18	41654	5.37	40026	6.58	38246	7.50	36288	8.26	34102	8.89	31585	9.40
	24	52318	9.78	50321	9.86	48256	10.41	46101	11.24	43816	12.17	41294	13.04
	30	58365	13.44	56347	13.83	54408	14.76	52317	15.86	49845	16.94	46678	17.73
870	12	43061	7.90	41837	8.82	40572	9.80	39255	10.74	37862	11.64	36361	12.49
	18	52143	10.54	50862	12.20	49508	13.44	48074	14.56	46552	15.57	44927	16.46
	24	65492	19.19	63904	19.31	62287	19.56	60631	20.29	58932	21.27	57179	22.39
	30	73061	26.36	71419	26.66	69868	27.58	68319	28.78	66701	30.13	64947	31.53
1150	12	56919	18.25	56002	19.39	55064	20.71	54109	22.01	53135	23.28	52135	24.52
	18	68924	24.34	67967	26.85	66979	28.60	65959	30.26	64905	31.82	63816	33.30
	24	86570	44.33	85368	44.31	84164	44.39	82943	44.84	81706	45.59	80451	46.59
	30	96574	60.89	95310	60.97	94103	61.82	92930	63.02	91766	64.45	90593	66.06

RPM	PITCH	1 1/2" SP		2" SP		2 1/2" SP		3" SP		3 1/2" SP		4" SP		4 1/2" SP	
		CFM	BHP	CFM	BHP	CFM	BHP	CFM	BHP	CFM	BHP	CFM	BHP	CFM	BHP
695	12	20472	7.65												
	18	28447	9.78												
	24	38255	13.68												
	30	42790	18.03												
870	12	34702	13.28	30484	14.60	22398	14.83								
	18	43182	17.25	39171	18.53	33676	19.38								
	24	55354	23.57	51333	25.74	46031	27.09								
	30	62075	32.88	57951	34.88	51684	35.47								
1150	12	51105	25.73	48921	28.04	46504	30.19	43713	32.13	40251	33.73	35310	34.63	27365	33.96
	18	62688	34.68	60309	37.19	57736	39.36	54914	41.24	51740	42.82	47992	44.09	42968	44.92
	24	79178	47.79	76568	50.60	73848	53.68	70965	56.73	67817	59.48	64184	61.63	59349	62.66
	30	89394	67.80	86855	71.46	84001	75.11	80637	78.33	76553	80.59	71838	81.58	67093	82.08

- Notes:**
- 1) Performance shown is for Installation Type D: ducted inlet, ducted outlet.
 - 2) Performance ratings do not include the effects of appurtenances in the airstream.
 - 3) Power rating (BHP) does not include drive losses.

VXD - Direct Drive Fan Data

Vaneaxial Fan

060

Wheel Diameter = 60 in.	Maximum RPM = 1150
Tip Speed, FPM = 15.71 x RPM	Bare Fan Weight = 2000 lbs.
Inlet & Outlet Diameter (Area) = 60.63 in. (20.05 sq.ft.)	

RPM	PITCH	0" SP		1/4" SP		1/2" SP		3/4" SP		1" SP		1 1/4" SP		1 1/2" SP		2" SP	
		CFM	BHP	CFM	BHP	CFM	BHP	CFM	BHP	CFM	BHP	CFM	BHP	CFM	BHP	CFM	BHP
695	12	47186	6.82	45477	7.85	43691	8.91	41792	9.90	39712	10.84	37342	11.69	34453	12.42	23573	12.75
	18	57139	9.10	55345	10.83	53417	12.14	51341	13.28	49090	14.27	46620	15.11	43847	15.81	36272	16.77
	24	71767	16.57	69554	16.62	67284	17.19	64941	18.19	62507	19.41	59940	20.70	57159	21.90	49834	23.41
	30	80061	22.76	77799	23.20	75653	24.35	73442	25.78	71014	27.32	68184	28.76	64711	29.89	56115	30.65
870	12	59068	13.38	57713	14.62	56321	15.98	54888	17.30	53400	18.57	51838	19.79	50178	20.96	46402	23.10
	18	71526	17.84	70111	20.23	68631	21.99	67081	23.61	65456	25.09	63749	26.45	61950	27.68	58013	29.80
	24	89838	32.50	88075	32.47	86291	32.80	84472	33.59	82617	34.73	80721	36.11	78777	37.65	74682	40.86
	30	100220	44.65	98382	44.93	96644	46.05	94933	47.54	93195	49.27	91381	51.14	89443	53.07	84939	56.70
1150	12	78078	30.91	77063	32.40	76024	34.23	74973	36.03	73906	37.80	72820	39.53	71710	41.23	69406	44.53
	18	94546	41.21	93486	44.89	92398	47.33	91282	49.66	90136	51.89	88960	54.02	87751	56.05	85231	59.80
	24	118751	75.07	117414	75.06	116082	75.04	114735	75.43	113372	76.20	111994	77.28	110600	78.64	107763	82.01

RPM	PITCH	2 1/2" SP		3" SP		3 1/2" SP		4" SP		4 1/2" SP		5" SP		5 1/2" SP		6" SP	
		CFM	BHP	CFM	BHP	CFM	BHP	CFM	BHP	CFM	BHP	CFM	BHP	CFM	BHP	CFM	BHP
870	12	41450	24.81	32917	25.30												
	18	53422	31.48	47503	32.68												
	24	70111	43.76	64400	45.71												
	30	79087	59.18	72095	59.99												
1150	12	66950	47.67	64281	50.63	61301	53.38	57839	55.80	53544	57.73	47547	58.67	38552	57.67	31396	57.11
	18	82559	63.17	79711	66.18	76649	68.84	73311	71.18	69586	73.19	65251	74.85	59702	76.00		
	24	104849	85.95	101834	90.17	98682	94.41	95330	98.41								

- Notes:**
- 1) Performance shown is for Installation Type D: ducted inlet, ducted outlet.
 - 2) Performance ratings do not include the effects of appurtenances in the airstream.
 - 3) Power rating (BHP) does not include drive losses.

Belt Drive Dimensional Data - VXB

Vaneaxial Fans

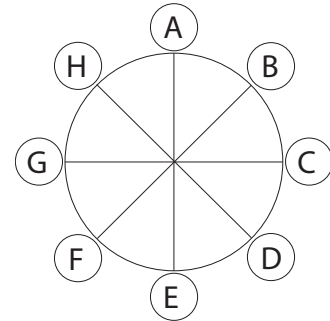
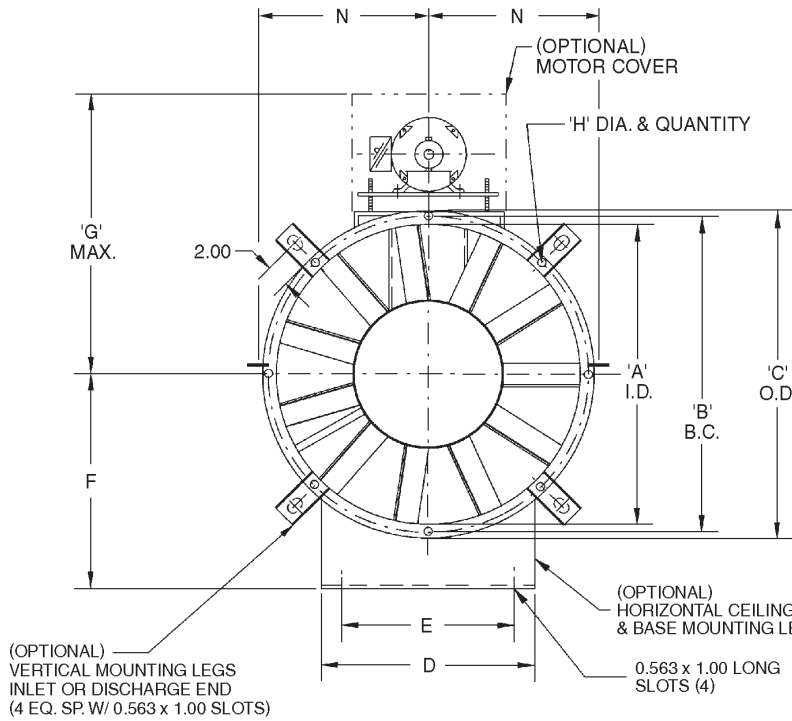

Discharge View
(see notes)

(OPTIONAL)
VERTICAL MOUNTING LEGS
INLET OR DISCHARGE END
(4 EQ. SP. W/ 0.563 x 1.00 SLOTS)

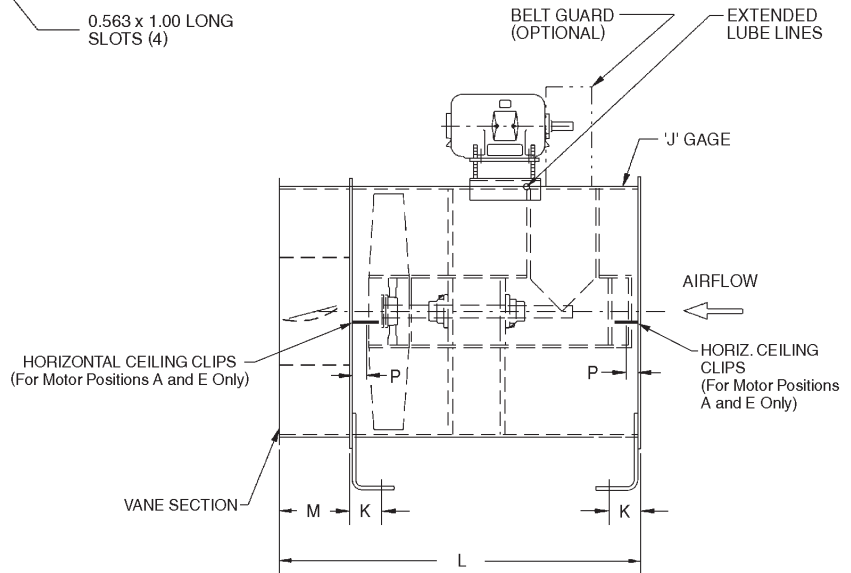

Notes:

1. Approximate fan weights are less motor, drive and accessories.
2. Propeller is eight-bladed cast aluminum.
3. Base mounting legs are used for motor positions A, B and H.
4. Horizontal ceiling brackets are used for motor positions D and F.
5. Horizontal ceiling clips are used for motor positions A and E.
6. For horizontal ceiling motor positions C and G, see page 16.
7. Dimensions should not be used for construction. Certified drawings are available upon request.

SIZE	A	B	C	D	E	F	G	H	J	K	L / MOTOR FRAME SIZE				M	N	P	UNIT WEIGHT
											DESIGN 1	MAX. MTR.	DESIGN 2	MAX. MTR.				
012	12.19	13.50	14.38	11.00	9.00	11.00	26.00	.438-8	14	1.68	29.63	184	—	—	5.63	7.19	3.08	120
015	15.19	16.50	17.44	14.00	12.00	13.00	27.50	.438-8	12	1.71	29.63	184	—	—	5.63	8.69	3.10	150
018	18.19	19.81	21.19	17.00	15.00	14.50	30.00	.438-8	12	1.71	33.63	215	—	—	5.63	10.16	3.10	200
021	21.22	22.97	24.22	20.00	18.00	16.00	31.50	.438-8	12	1.71	34.38	215	—	—	6.38	12.17	3.10	250
024	24.25	26.06	27.25	22.00	18.00	18.00	36.25	.438-8	12	1.71	35.38	215	39.38	286	7.38	13.69	3.10	350
030	30.31	32.19	33.31	29.00	25.00	21.50	40.25	.438-8	12	1.71	37.06	215	45.06	286	9.06	16.74	3.10	550
036	36.38	38.18	39.38	35.00	31.00	25.00	44.75	.438-16	10	1.73	47.13	256	53.13	326	11.13	19.75	3.13	850
042	42.44	44.81	46.44	40.00	36.00	29.00	49.25	.563-16	10	1.73	48.69	256	54.69	326	12.69	23.28	3.13	1050
048	48.50	50.88	52.50	46.00	42.00	33.25	54.25	.563-16	10	1.73	56.50	286	62.50	405	14.50	26.31	3.13	1400
054	54.56	57.00	58.56	52.00	48.00	36.25	57.25	.563-16	7	1.78	64.31	286	70.31	405	16.31	29.38	3.18	2100
060	60.63	63.00	64.63	56.00	52.00	39.25	60.25	.563-16	7	1.78	66.31	286	72.31	405	18.31	32.38	3.18	2500

VXB - Belt Drive Dimensional Data

Vaneaxial Fans - Offset Ceiling Hangers

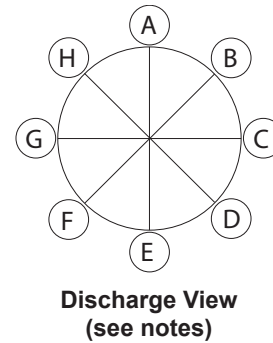
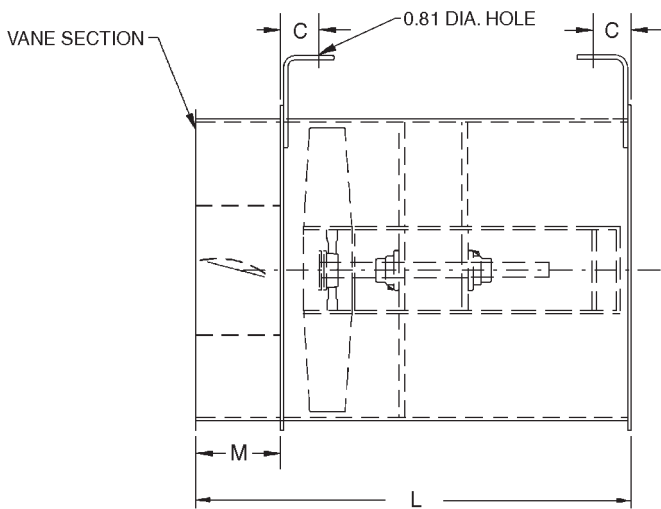
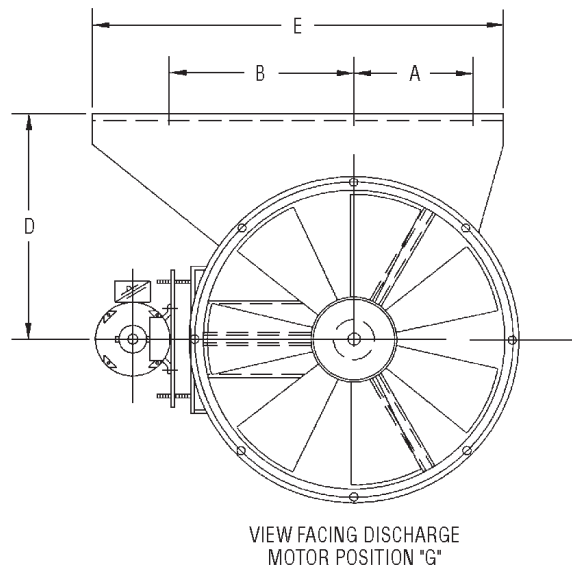
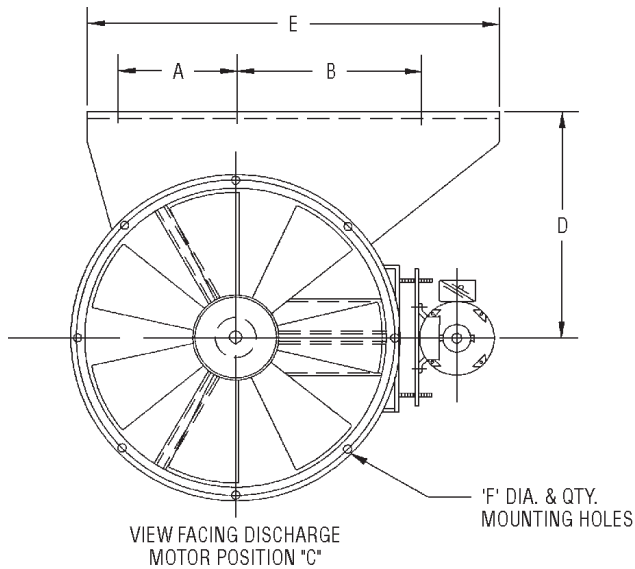

Notes:

1. Approximate fan weights are less motor, drive and accessories.
2. Propeller is eight-bladed cast aluminum.
3. Available only in motor positions C and G.
4. Dimensions should not be used for construction. Certified drawings are available upon request.

SIZE	A	B	C	D	E	F	L / MOTOR FRAME SIZE				M
							DESIGN 1	MAX. MTR.	DESIGN 2	MAX. MTR.	
012	7.38	17.50	2.88	11.00	28.88	0.44-3	29.63	184	—	—	5.63
015	8.88	19.00	2.88	13.00	31.88	0.44-3	29.63	184	—	—	5.63
018	10.38	21.25	2.88	14.50	35.63	0.44-3	33.63	215	—	—	5.63
021	11.88	22.75	2.88	16.00	38.63	0.44-3	34.38	215	—	—	6.38
024	13.38	25.75	2.88	18.00	43.13	0.50-3	35.38	215	39.38	286	7.38
030	16.13	28.50	2.88	21.50	48.63	0.50-3	37.06	215	45.06	286	9.06
036	19.44	31.75	2.88	25.00	55.19	0.50-5	47.13	256	53.13	326	11.13
042	22.50	35.50	2.88	29.00	62.00	0.63-5	48.69	256	54.69	326	12.69
048	25.50	39.50	3.13	33.25	69.00	0.63-5	56.50	286	62.50	405	14.50
054	28.56	42.25	3.13	36.25	74.81	0.63-5	64.31	286	70.31	405	16.31
060	31.63	46.25	3.13	39.25	81.88	0.63-5	66.31	286	72.31	405	18.31

Belt Drive Fan Data - VXB

Vaneaxial Fan

Shown with optional motor cover



012

Wheel Diameter = 12 in.	Maximum RPM = 5490
Tip Speed, FPM = 3.14 x RPM	Bare Fan Weight = 120 lbs.
Inlet & Outlet Diameter (Area) = 12.19 in. (0.81 sq.ft.)	

CFM	0" SP		1/4" SP		1/2" SP		3/4" SP		1" SP		1 1/4" SP	
	RPM	BHP	RPM	BHP	RPM	BHP	RPM	BHP	RPM	BHP	RPM	BHP
972	1409	0.07	1656	0.12	1897	0.19	2170	0.28				
1134	1644	0.11	1854	0.17	2063	0.24	2272	0.33	2510	0.43		
1296	1879	0.16	2061	0.22	2248	0.31	2428	0.40	2614	0.50	2819	0.62
1458	2114	0.23	2273	0.30	2442	0.39	2605	0.48	2764	0.59	2930	0.70
1620	2349	0.31	2489	0.39	2642	0.48	2792	0.59	2936	0.70	3081	0.82
1782	2584	0.42	2710	0.49	2848	0.59	2987	0.71	3119	0.83	3250	0.95
1944	2819	0.54	2933	0.62	3059	0.73	3186	0.85	3311	0.97	3433	1.10
2106	3054	0.69	3158	0.77	3273	0.88	3391	1.01	3507	1.14	3621	1.28
2268	3289	0.86	3384	0.95	3489	1.06	3598	1.19	3708	1.33	3817	1.48
2430	3524	1.05	3612	1.15	3709	1.27	3811	1.40	3913	1.55	4016	1.70
2592	3758	1.28	3841	1.38	3930	1.50	4025	1.64	4121	1.79	4217	1.95
2754	3993	1.53	4071	1.64	4153	1.77	4242	1.91	4332	2.07	4423	2.23
2916	4228	1.82	4302	1.94	4379	2.07	4460	2.21	4545	2.37	4630	2.54
3078	4463	2.14	4531	2.26	4604	2.40	4682	2.55	4761	2.71	4841	2.90
3240	4698	2.50	4762	2.62	4832	2.77	4904	2.92	4978	3.09	5055	3.27
3402	4933	2.89	4994	3.02	5059	3.17	5128	3.33	5199	3.50	5269	3.68
3564	5168	3.33	5226	3.46	5287	3.61	5353	3.78	5419	3.95	5488	4.14
3725	5403	3.80	5459	3.94								

CFM	1 1/2" SP		2" SP		2 1/2" SP		3" SP		3 1/2" SP		4" SP		4 1/2" SP	
	RPM	BHP	RPM	BHP	RPM	BHP	RPM	BHP	RPM	BHP	RPM	BHP	RPM	BHP
1296	3048	0.76												
1458	3109	0.83	3515	1.16										
1620	3228	0.94	3556	1.24										
1782	3382	1.08	3655	1.36	3964	1.71	4304	2.12						
1944	3553	1.24	3793	1.53	4053	1.85	4340	2.24	4652	2.69				
2106	3733	1.42	3954	1.72	4181	2.05	4424	2.41	4690	2.83	4978	3.31		
2268	3921	1.63	4126	1.94	4333	2.27	4545	2.63	4775	3.03	5020	3.47	5286	3.98
2430	4114	1.86	4310	2.19	4499	2.53	4694	2.89	4893	3.28	5107	3.70	5334	4.18
2592	4312	2.12	4497	2.46	4676	2.82	4856	3.19	5039	3.58	5228	4.00	5426	4.45
2754	4512	2.40	4689	2.76	4861	3.13	5028	3.51	5197	3.91	5371	4.34		
2916	4716	2.72	4885	3.09	5049	3.48	5209	3.88	5367	4.28				
3078	4922	3.07	5084	3.46	5240	3.86	5393	4.27						
3240	5131	3.45	5285	3.85	5438	4.27								
3402	5344	3.88	5490	4.29										

- Notes:**
- 1) Performance shown is for Installation Type D: ducted inlet, ducted outlet.
 - 2) Performance ratings do not include the effects of appurtenances in the airstream.
 - 3) Power rating (BHP) does not include drive losses.

VXB - Belt Drive Fan Data

Vaneaxial Fan

015

Wheel Diameter = 15 in.	Maximum RPM = 4935
Tip Speed, FPM = 3.93 x RPM	Bare Fan Weight = 150 lbs.
Inlet & Outlet Diameter (Area) = 15.19 in. (1.26 sq.ft.)	

CFM	0" SP		1/4" SP		1/2" SP		3/4" SP		1" SP		1 1/4" SP		1 1/2" SP	
	RPM	BHP	RPM	BHP	RPM	BHP	RPM	BHP	RPM	BHP	RPM	BHP	RPM	BHP
1510	1062	0.07	1275	0.14	1482	0.23	1711	0.35						
1761	1238	0.10	1423	0.19	1602	0.28	1778	0.40	1977	0.54				
2012	1414	0.16	1577	0.25	1735	0.35	1890	0.47	2044	0.60	2215	0.76		
2263	1591	0.22	1736	0.32	1877	0.44	2017	0.56	2155	0.70	2291	0.85	2437	1.01
2514	1767	0.30	1899	0.42	2026	0.54	2152	0.67	2278	0.82	2400	0.97	2524	1.13
2765	1944	0.40	2064	0.53	2180	0.66	2295	0.80	2409	0.95	2523	1.11	2635	1.28
3016	2120	0.52	2231	0.66	2337	0.80	2443	0.95	2549	1.11	2654	1.28	2758	1.45
3267	2297	0.66	2400	0.81	2499	0.96	2596	1.12	2693	1.29	2791	1.47	2888	1.65
3518	2473	0.83	2570	0.99	2661	1.15	2752	1.32	2842	1.49	2934	1.68	3024	1.87
3769	2650	1.02	2739	1.19	2825	1.36	2911	1.54	2995	1.72	3080	1.92	3165	2.12
4020	2826	1.24	2910	1.42	2991	1.60	3072	1.79	3151	1.98	3231	2.18	3310	2.39
4271	3003	1.48	3083	1.68	3159	1.87	3234	2.07	3309	2.27	3385	2.48	3459	2.70
4522	3179	1.76	3254	1.97	3327	2.17	3399	2.38	3469	2.59	3541	2.81	3610	3.03
4773	3356	2.07	3428	2.29	3497	2.51	3564	2.72	3632	2.95	3698	3.17	3765	3.40
5024	3532	2.41	3600	2.64	3666	2.87	3730	3.10	3795	3.33	3858	3.57	3923	3.81
5275	3708	2.79	3774	3.04	3836	3.28	3898	3.51	3960	3.76	4020	4.00	4082	4.26
5526	3885	3.21	3947	3.46	4007	3.72	4068	3.97	4125	4.22	4183	4.47	4241	4.74
5777	4061	3.67	4121	3.94	4178	4.20	4236	4.46	4291	4.74	4348	4.99	4402	5.26
6028	4238	4.17	4294	4.44	4351	4.72	4405	4.99	4460	5.27	4513	5.55	4567	5.83
6279	4414	4.71	4470	5.00	4522	5.29	4574	5.57	4628	5.86	4678	6.14	4730	6.43

CFM	2" SP		2 1/2" SP		3" SP		3 1/2" SP		4" SP		4 1/2" SP		5" SP		5 1/2" SP	
	RPM	BHP	RPM	BHP	RPM	BHP	RPM	BHP	RPM	BHP	RPM	BHP	RPM	BHP	RPM	BHP
2514	2796	1.52														
2765	2862	1.65	3124	2.12												
3016	2962	1.83	3174	2.25	3421	2.78										
3267	3078	2.04	3267	2.45	3466	2.92	3696	3.50								
3518	3201	2.27	3378	2.70	3566	3.16	3739	3.67	3954	4.29						
3769	3332	2.53	3499	2.98	3662	3.45	3827	3.94	4001	4.49	4194	5.14				
4020	3468	2.83	3625	3.29	3779	3.77	3933	4.27	4087	4.80	4249	5.38	4428	6.06	4643	6.91
4271	3607	3.15	3756	3.62	3903	4.12	4048	4.64	4193	5.18	4340	5.75	4490	6.36	4653	7.04
4522	3753	3.50	3893	3.99	4031	4.50	4170	5.04	4305	5.58	4444	6.17	4581	6.76		
4773	3898	3.88	4031	4.39	4165	4.92	4297	5.47	4426	6.03	4557	6.62	4685	7.22		
5024	4049	4.31	4177	4.84	4303	5.38	4428	5.94	4552	6.52	4676	7.12				
5275	4202	4.77	4323	5.31	4444	5.87	4564	6.45	4683	7.05						
5526	4357	5.27	4473	5.83	4588	6.40	4702	7.00								
5777	4513	5.81	4623	6.38	4734	6.97										
6028	4673	6.40	4779	6.99												
6279	4832	7.02	4935	7.64												

- Notes:**
- 1) Performance shown is for Installation Type D: ducted inlet, ducted outlet.
 - 2) Performance ratings do not include the effects of appurtenances in the airstream.
 - 3) Power rating (BHP) does not include drive losses.

Belt Drive Fan Data - VXB

Vaneaxial Fan

018

Wheel Diameter = 18 in.	Maximum RPM = 4483
Tip Speed, FPM = 4.71 x RPM	Bare Fan Weight = 200 lbs.
Inlet & Outlet Diameter (Area) = 18.19 in. (1.80 sq.ft.)	

CFM	0" SP		1/4" SP		1/2" SP		3/4" SP		1" SP		1 1/4" SP		1 1/2" SP		2" SP	
	RPM	BHP	RPM	BHP	RPM	BHP	RPM	BHP	RPM	BHP	RPM	BHP	RPM	BHP	RPM	BHP
2160	871	0.08	1062	0.18	1267	0.32										
2520	1016	0.13	1177	0.24	1350	0.39	1530	0.56								
2880	1161	0.19	1301	0.32	1449	0.47	1603	0.65	1763	0.86						
3240	1307	0.27	1431	0.41	1559	0.58	1693	0.76	1831	0.97	1973	1.21	2139	1.50		
3600	1452	0.37	1564	0.53	1677	0.70	1796	0.90	1919	1.11	2042	1.35	2171	1.61		
3960	1597	0.49	1699	0.66	1801	0.85	1907	1.05	2016	1.28	2128	1.52	2241	1.78	2478	2.37
4320	1742	0.63	1836	0.82	1929	1.02	2024	1.24	2123	1.47	2224	1.72	2327	1.99	2535	2.57
4680	1887	0.80	1974	1.01	2059	1.22	2147	1.45	2236	1.69	2328	1.95	2423	2.23	2612	2.82
5040	2033	1.01	2113	1.23	2192	1.45	2272	1.69	2354	1.94	2439	2.21	2525	2.49	2700	3.10
5400	2178	1.24	2254	1.48	2327	1.71	2402	1.97	2477	2.23	2555	2.51	2634	2.80	2795	3.42
5760	2323	1.50	2395	1.76	2464	2.01	2533	2.27	2603	2.55	2675	2.83	2748	3.14	2898	3.78
6120	2468	1.80	2535	2.07	2601	2.34	2665	2.62	2732	2.91	2799	3.20	2867	3.51	3005	4.17
6480	2613	2.14	2677	2.42	2738	2.71	2800	3.00	2862	3.30	2924	3.61	2988	3.93	3118	4.60
6840	2758	2.51	2819	2.82	2877	3.12	2936	3.42	2994	3.74	3053	4.06	3113	4.39	3235	5.09
7200	2904	2.93	2961	3.25	3017	3.57	3072	3.89	3128	4.21	3183	4.54	3240	4.89	3354	5.60
7560	3049	3.39	3104	3.73	3157	4.06	3209	4.39	3262	4.73	3315	5.08	3369	5.44	3477	6.18
7920	3194	3.90	3246	4.25	3298	4.60	3348	4.95	3399	5.31	3449	5.67	3499	6.03	3602	6.79
8280	3339	4.46	3390	4.83	3438	5.19	3487	5.55	3535	5.92	3583	6.30	3631	6.68	3728	7.46
8640	3484	5.06	3533	5.45	3580	5.83	3626	6.21	3672	6.59	3719	6.98	3765	7.38	3858	8.19
9000	3630	5.72	3676	6.12	3721	6.52	3766	6.92	3810	7.31	3854	7.72	3898	8.12	3988	8.96

CFM	2 1/2" SP		3" SP		3 1/2" SP		4" SP		4 1/2" SP		5" SP		5 1/2" SP		6" SP		6 1/2" SP	
	RPM	BHP	RPM	BHP	RPM	BHP	RPM	BHP	RPM	BHP	RPM	BHP	RPM	BHP	RPM	BHP	RPM	BHP
4320	2763	3.27																
4680	2807	3.48	3023	4.27														
5040	2878	3.77	3061	4.50	3264	5.37												
5400	2960	4.10	3127	4.83	3299	5.63	3491	6.57										
5760	3051	4.47	3205	5.21	3362	6.00	3525	6.87	3705	7.87								
6120	3149	4.88	3293	5.63	3439	6.43	3587	7.28	3741	8.21	3907	9.25						
6480	3252	5.33	3387	6.10	3525	6.91	3663	7.77	3802	8.67	3947	9.64	4103	10.74	4278	12.00		
6840	3359	5.82	3488	6.62	3616	7.43	3747	8.31	3878	9.22	4011	10.18	4147	11.19	4921	12.31	4449	13.58
7200	3474	6.37	3593	7.17	3714	8.01	3838	8.90	3961	9.82	4084	10.77	4210	11.78	4342	12.86	4476	14.01
7560	3588	6.95	3701	7.78	3817	8.64	3933	9.54	4051	10.48	4168	11.45	4286	12.45	4406	13.50		
7920	3706	7.59	3814	8.44	3923	9.31	4033	10.22	4144	11.17	4257	12.16	4369	13.18	4483	14.24		
8280	3828	8.28	3930	9.15	4033	10.04	4138	10.96	4243	11.93	4350	12.93	4457	13.97				
8640	3952	9.02	4049	9.90	4147	10.81	4246	11.76	4347	12.75	4448	13.76						
9000	4078	9.82	4170	10.72	4262	11.64	4357	12.61	4454	13.62								

- Notes:**
- 1) Performance shown is for Installation Type D: ducted inlet, ducted outlet.
 - 2) Performance ratings do not include the effects of appurtenances in the airstream.
 - 3) Power rating (BHP) does not include drive losses.

VXB - Belt Drive Fan Data

Vaneaxial Fan

021

Wheel Diameter = 21 in.	Maximum RPM = 3574
Tip Speed, FPM = 5.50 x RPM	Bare Fan Weight = 250 lbs.
Inlet & Outlet Diameter (Area) = 21.22 in. (2.45 sq.ft.)	

CFM	0" SP		1/4" SP		1/2" SP		3/4" SP		1" SP		1 1/4" SP		1 1/2" SP	
	RPM	BHP	RPM	BHP	RPM	BHP	RPM	BHP	RPM	BHP	RPM	BHP	RPM	BHP
2940	747	0.11	910	0.25	1087	0.44								
3430	871	0.17	1009	0.33	1157	0.53	1312	0.77						
3920	996	0.26	1116	0.43	1242	0.64	1374	0.89	1511	1.17				
4410	1120	0.36	1227	0.56	1337	0.78	1452	1.04	1570	1.32	1692	1.64	1833	2.04
4900	1245	0.50	1341	0.72	1438	0.95	1539	1.22	1645	1.51	1751	1.83	1860	2.19
5390	1369	0.66	1457	0.90	1544	1.16	1635	1.43	1728	1.74	1824	2.07	1921	2.42
5880	1494	0.86	1574	1.12	1654	1.39	1736	1.69	1820	2.00	1907	2.34	1994	2.70
6370	1618	1.10	1693	1.38	1766	1.67	1840	1.97	1917	2.30	1996	2.66	2076	3.03
6860	1743	1.37	1812	1.67	1880	1.98	1948	2.30	2018	2.65	2091	3.01	2164	3.39
7350	1867	1.68	1932	2.01	1995	2.34	2059	2.68	2124	3.03	2190	3.41	2258	3.81
7840	1992	2.04	2053	2.39	2112	2.74	2171	3.10	2231	3.47	2293	3.86	2356	4.27
8330	2116	2.45	2173	2.82	2230	3.19	2285	3.56	2342	3.95	2399	4.36	2457	4.78
8820	2240	2.91	2295	3.30	2348	3.69	2401	4.08	2454	4.49	2507	4.91	2562	5.35
9310	2365	3.42	2416	3.83	2467	4.24	2517	4.66	2567	5.08	2617	5.52	2668	5.97
9800	2489	3.99	2539	4.43	2586	4.85	2634	5.29	2681	5.73	2729	6.19	2777	6.66
10290	2614	4.62	2661	5.08	2706	5.53	2752	5.99	2797	6.44	2842	6.92	2888	7.40
10780	2738	5.31	2783	5.79	2827	6.26	2870	6.74	2913	7.22	2957	7.71	3000	8.21
11270	2863	6.07	2906	6.57	2948	7.07	2989	7.56	3030	8.06	3071	8.57	3113	9.09
11760	2987	6.90	3029	7.42	3069	7.93	3109	8.45	3148	8.97	3188	9.51	3227	10.04
12250	3112	7.80	3151	8.34	3190	8.88	3228	9.42	3266	9.96	3304	10.51	3342	11.07

CFM	2" SP		2 1/2" SP		3" SP		3 1/2" SP		4" SP		4 1/2" SP		5" SP	
	RPM	BHP	RPM	BHP	RPM	BHP	RPM	BHP	RPM	BHP	RPM	BHP	RPM	BHP
5390	2125	3.23												
5880	2173	3.50	2368	4.45										
6370	2239	3.84	2406	4.74	2591	5.81								
6860	2314	4.22	2467	5.13	2624	6.13	2799	7.31						
7350	2396	4.66	2537	5.58	2680	6.57	2829	7.67	2992	8.94				
7840	2484	5.14	2616	6.08	2747	7.08	2883	8.17	3022	9.35	3175	10.70		
8330	2577	5.68	2699	6.64	2823	7.67	2948	8.75	3076	9.92	3207	11.17	3349	12.59
8820	2673	6.27	2788	7.26	2904	8.30	3021	9.41	3139	10.57	3260	11.81	3384	13.14
9310	2773	6.92	2880	7.93	2990	9.00	3100	10.12	3211	11.31	3324	12.55	3438	13.85
9800	2876	7.63	2976	8.67	3079	9.76	3183	10.90	3289	12.11	3395	13.36	3501	14.66
10290	2981	8.41	3076	9.47	3173	10.58	3271	11.75	3371	12.97	3471	14.25		
10780	3088	9.25	3178	10.33	3269	11.48	3362	12.66	3457	13.91				
11270	3197	10.16	3282	11.27	3369	12.44	3457	13.65						
11760	3307	11.14	3388	12.28	3471	13.49	3554	14.72						
12250	3419	12.20	3496	13.38	3574	14.59								

- Notes:**
- 1) Performance shown is for Installation Type D: ducted inlet, ducted outlet.
 - 2) Performance ratings do not include the effects of appurtenances in the airstream.
 - 3) Power rating (BHP) does not include drive losses.

Belt Drive Fan Data - VXB

Vaneaxial Fan

024

Wheel Diameter = 24 in.	Maximum RPM = 2963
Tip Speed, FPM = 6.28 x RPM	Bare Fan Weight = 350 lbs.
Inlet & Outlet Diameter (Area) = 24.25 in. (3.21 sq.ft.)	

CFM	0" SP		1/4" SP		1/2" SP		3/4" SP		1" SP		1 1/4" SP		1 1/2" SP		2" SP	
	RPM	BHP	RPM	BHP	RPM	BHP	RPM	BHP	RPM	BHP	RPM	BHP	RPM	BHP	RPM	BHP
3852	603	0.12	737	0.28	867	0.50	990	0.75								
4494	704	0.18	819	0.37	932	0.60	1041	0.87	1146	1.17						
5136	804	0.27	906	0.49	1005	0.73	1103	1.01	1197	1.33	1289	1.67				
5778	905	0.39	996	0.63	1083	0.89	1171	1.18	1258	1.51	1341	1.86	1423	2.24		
6420	1005	0.54	1088	0.80	1166	1.08	1246	1.39	1325	1.72	1403	2.09	1478	2.49	1625	3.33
7062	1106	0.71	1182	1.00	1253	1.30	1325	1.63	1397	1.98	1469	2.35	1539	2.76	1675	3.64
7704	1207	0.93	1277	1.23	1342	1.56	1408	1.91	1473	2.27	1540	2.66	1606	3.08	1734	3.99
8346	1307	1.18	1373	1.51	1433	1.86	1493	2.22	1554	2.61	1615	3.01	1676	3.44	1797	4.37
8988	1408	1.47	1469	1.83	1525	2.20	1581	2.59	1637	2.99	1694	3.41	1751	3.85	1864	4.81
9630	1508	1.81	1566	2.19	1619	2.58	1671	2.99	1723	3.42	1775	3.85	1829	4.31	1935	5.29
10272	1609	2.19	1663	2.60	1713	3.02	1762	3.45	1811	3.90	1860	4.35	1909	4.83	2009	5.83
10914	1709	2.63	1761	3.06	1809	3.51	1855	3.96	1901	4.43	1947	4.90	1993	5.40	2086	6.43
11556	1810	3.12	1859	3.58	1904	4.05	1948	4.53	1991	5.01	2035	5.51	2079	6.03	2166	7.10
12198	1910	3.68	1957	4.16	2000	4.65	2042	5.14	2084	5.66	2124	6.17	2165	6.71	2248	7.82
12840	2011	4.29	2055	4.79	2097	5.31	2137	5.83	2176	6.37	2215	6.90	2254	7.45	2332	8.61
13482	2112	4.96	2154	5.49	2194	6.03	2232	6.58	2269	7.13	2307	7.69	2344	8.26	2418	9.46
14124	2212	5.71	2252	6.25	2291	6.82	2328	7.39	2364	7.98	2399	8.54	2435	9.15	2506	10.39
14766	2313	6.52	2352	7.10	2389	7.69	2424	8.28	2458	8.88	2493	9.48	2527	10.10	2594	11.38
15408	2413	7.41	2451	8.01	2486	8.63	2520	9.25	2553	9.87	2586	10.48	2619	11.13	2684	12.46
16050	2514	8.37	2550	9.00	2584	9.63	2617	10.28	2649	10.93	2681	11.57	2712	12.23	2775	13.60

CFM	2 1/2" SP		3" SP		3 1/2" SP		4" SP		4 1/2" SP		5" SP		5 1/2" SP		6" SP	
	RPM	BHP	RPM	BHP	RPM	BHP	RPM	BHP	RPM	BHP	RPM	BHP	RPM	BHP	RPM	BHP
7062	1809	4.59														
7704	1857	4.98	1980	6.01												
8346	1913	5.39	2026	6.48	2140	7.60										
8988	1975	5.84	2081	6.96	2186	8.13	2292	9.34								
9630	2040	6.35	2142	7.49	2241	8.70	2339	9.96	2437	11.25						
10272	2109	6.92	2206	8.08	2301	9.31	2394	10.61	2485	11.95	2577	13.32	2672	14.72		
10914	2180	7.54	2273	8.73	2364	9.98	2454	11.30	2541	12.68	2627	14.10	2713	15.56	2801	17.03
11556	2255	8.23	2343	9.43	2430	10.71	2516	12.05	2600	13.46	2682	14.90	2764	16.40	2846	17.95
12198	2332	8.99	2416	10.22	2499	11.51	2582	12.88	2664	14.31	2743	15.78	2821	17.31	2898	18.89
12840	2412	9.82	2492	11.07	2571	12.40	2650	13.77	2728	15.21	2805	16.72	2881	18.28		
13482	2493	10.70	2569	12.00	2645	13.33	2721	14.74	2797	16.22	2871	17.74	2944	19.32		
14124	2577	11.66	2649	12.99	2722	14.38	2794	15.81	2866	17.29	2938	18.84				
14766	2663	12.70	2731	14.06	2800	15.48	2869	16.93	2939	18.45						
15408	2749	13.80	2815	15.22	2881	16.66	2947	18.15								
16050	2837	15.00	2900	16.45	2963	17.92										

- Notes:
- 1) Performance shown is for Installation Type D: ducted inlet, ducted outlet.
 - 2) Performance ratings do not include the effects of appurtenances in the airstream.
 - 3) Power rating (BHP) does not include drive losses.

VXB - Belt Drive Fan Data

Vaneaxial Fan

030

Wheel Diameter = 30 in.	Maximum RPM = 2475
Tip Speed, FPM = 7.85 x RPM	Bare Fan Weight = 550 lbs.
Inlet & Outlet Diameter (Area) = 30.31 in. (5.01 sq.ft.)	

CFM	0" SP		1/4" SP		1/2" SP		3/4" SP		1" SP		1 1/4" SP		1 1/2" SP		2" SP	
	RPM	BHP	RPM	BHP	RPM	BHP	RPM	BHP	RPM	BHP	RPM	BHP	RPM	BHP	RPM	BHP
6852	549	0.27	644	0.56	737	0.91	825	1.33	912	1.78						
7994	641	0.42	722	0.75	802	1.13	881	1.57	956	2.06	1030	2.59				
9136	733	0.63	805	1.00	874	1.42	944	1.88	1012	2.39	1078	2.95	1143	3.55		
10278	824	0.90	889	1.31	950	1.76	1012	2.25	1074	2.78	1135	3.36	1194	3.98	1309	5.32
11420	916	1.23	975	1.69	1030	2.18	1085	2.70	1141	3.26	1197	3.86	1252	4.50	1357	5.89
12562	1007	1.64	1061	2.14	1112	2.67	1162	3.22	1212	3.81	1263	4.44	1314	5.10	1413	6.54
13704	1099	2.12	1149	2.67	1195	3.24	1241	3.83	1287	4.46	1334	5.11	1380	5.80	1473	7.27
14846	1190	2.70	1237	3.29	1280	3.90	1322	4.54	1365	5.20	1407	5.88	1450	6.59	1537	8.11
15988	1282	3.37	1326	4.01	1366	4.66	1405	5.33	1445	6.03	1484	6.75	1524	7.49	1604	9.06
17130	1374	4.15	1415	4.83	1453	5.52	1490	6.24	1526	6.97	1563	7.73	1600	8.51	1674	10.14
18272	1465	5.03	1504	5.75	1540	6.50	1575	7.25	1609	8.03	1643	8.82	1678	9.63	1747	11.33
19414	1557	6.04	1593	6.81	1628	7.59	1660	8.38	1693	9.20	1725	10.03	1757	10.88	1822	12.65
20556	1648	7.17	1683	7.98	1715	8.80	1747	9.64	1778	10.50	1808	11.37	1839	12.26	1900	14.10
21698	1740	8.43	1773	9.29	1804	10.15	1834	11.03	1863	11.94	1892	12.85	1921	13.78	1979	15.69
22840	1831	9.83	1863	10.73	1893	11.64	1921	12.57	1949	13.51	1977	14.46	2004	15.43	2059	17.42
23982	1923	11.38	1953	12.33	1981	13.28	2009	14.25	2036	15.23	2062	16.22	2089	17.25	2141	19.30
25124	2015	13.09	2043	14.07	2071	15.07	2097	16.08	2123	17.11	2148	18.15	2174	19.20	2223	21.34
26266	2106	14.95	2134	15.99	2160	17.02	2186	18.09	2210	19.16	2235	20.22	2259	21.32	2307	23.56
27408	2198	16.99	2224	18.08	2250	19.15	2274	20.25	2298	21.36	2322	22.48	2345	23.62	2391	25.93
28550	2289	19.21	2315	20.32	2340	21.47	2363	22.59	2386	23.75	2409	24.92	2431	26.08	2475	28.47

CFM	2 1/2" SP		3" SP		3 1/2" SP		4" SP		4 1/2" SP		5" SP		5 1/2" SP		6" SP	
	RPM	BHP	RPM	BHP	RPM	BHP	RPM	BHP	RPM	BHP	RPM	BHP	RPM	BHP	RPM	BHP
11420	1460	7.40														
12562	1508	8.11	1602	9.77												
13704	1563	8.88	1649	10.61	1735	12.42	1823	14.28								
14846	1621	9.76	1704	11.53	1784	13.41	1863	16.36	1943	17.36						
15988	1684	10.76	1762	12.57	1838	14.49	1912	16.50	1986	18.60	2060	20.75	2136	22.91		
17130	1749	11.87	1823	13.72	1895	15.67	1967	17.74	2036	19.89	2105	22.13	2173	24.40	2243	26.72
18272	1817	13.12	1887	15.00	1956	17.00	2024	19.10	2091	21.29	2156	23.58	2221	25.93	2285	28.37
19414	1888	14.49	1954	16.43	2020	18.47	2085	20.61	2149	22.84	2212	25.18	2274	27.58		
20556	1962	16.01	2024	18.00	2086	20.08	2148	22.27	2210	24.54	2270	26.91				
21698	2037	17.66	2096	19.72	2155	21.85	2214	24.07	2272	26.38	2330	28.78				
22840	2114	19.47	2170	21.58	2226	23.77	2282	26.04	2338	28.40						
23982	2193	21.42	2246	23.60	2299	25.85	2352	28.19								
25124	2273	23.54	2323	25.79	2374	28.12										
26266	2354	25.82	2402	28.15												
27408	2436	28.28														

- Notes:**
- 1) Performance shown is for Installation Type D: ducted inlet, ducted outlet.
 - 2) Performance ratings do not include the effects of appurtenances in the airstream.
 - 3) Power rating (BHP) does not include drive losses.

Belt Drive Fan Data - VXB

Vaneaxial Fan

036

Wheel Diameter = 36 in.	Maximum RPM = 2019
Tip Speed, FPM = 9.42 x RPM	Bare Fan Weight = 850 lbs.
Inlet & Outlet Diameter (Area) = 36.38 in. (7.21 sq.ft.)	

CFM	0" SP		1/4" SP		1/2" SP		3/4" SP		1" SP		1 1/4" SP		1 1/2" SP		2" SP	
	RPM	BHP	RPM	BHP	RPM	BHP	RPM	BHP	RPM	BHP	RPM	BHP	RPM	BHP	RPM	BHP
8664	402	0.26	491	0.64	578	1.12	660	1.69								
10108	469	0.41	546	0.84	621	1.35	694	1.95	764	2.63						
11552	536	0.61	604	1.09	670	1.64	735	2.27	798	2.98	859	3.74				
12996	603	0.86	664	1.40	722	1.99	781	2.65	839	3.38	894	4.19	949	5.04		
14440	670	1.19	725	1.77	777	2.41	830	3.10	883	3.86	935	4.70	985	5.59	1083	7.50
15884	737	1.58	788	2.22	835	2.90	883	3.64	931	4.43	979	5.28	1026	6.20	1117	8.19
17328	804	2.05	851	2.74	894	3.48	938	4.26	982	5.09	1027	5.97	1071	6.91	1156	8.96
18772	871	2.60	915	3.36	955	4.14	995	4.97	1036	5.84	1077	6.75	1117	7.72	1198	9.83
20216	938	3.25	979	4.06	1017	4.90	1054	5.78	1091	6.69	1129	7.64	1167	8.64	1243	10.79
21660	1005	4.00	1044	4.86	1079	5.76	1114	6.68	1149	7.64	1184	8.64	1219	9.67	1290	11.88
23104	1072	4.86	1108	5.77	1142	6.72	1175	7.69	1207	8.70	1240	9.74	1273	10.82	1339	13.09
24548	1139	5.82	1173	6.80	1205	7.80	1236	8.83	1267	9.88	1297	10.97	1328	12.09	1391	14.43
25992	1206	6.91	1239	7.94	1269	8.99	1298	10.08	1327	11.18	1356	12.32	1385	13.48	1444	15.90
27436	1273	8.13	1304	9.21	1333	10.32	1361	11.46	1389	12.62	1416	13.80	1443	15.01	1498	17.52
28880	1340	9.48	1370	10.62	1397	11.78	1424	12.97	1450	14.19	1476	15.42	1502	16.67	1556	19.28
30324	1407	10.98	1435	12.17	1462	13.39	1488	14.63	1513	15.89	1538	17.18	1562	18.49	1612	21.19
31768	1474	12.62	1501	13.87	1527	15.14	1551	16.44	1575	17.76	1599	19.10	1623	20.45	1670	23.24
33212	1541	14.42	1567	15.73	1592	17.06	1615	18.40	1638	19.77	1661	21.17	1684	22.57	1729	25.46
34656	1608	16.39	1633	17.75	1657	19.13	1680	20.53	1702	21.96	1724	23.39	1746	24.86	1789	27.85
36100	1675	18.52	1699	19.94	1722	21.37	1744	22.84	1766	24.31	1787	25.81	1808	27.32	1849	30.40

CFM	2 1/2" SP		3" SP		3 1/2" SP		4" SP		4 1/2" SP		5" SP		5 1/2" SP		6" SP		6 1/2" SP	
	RPM	BHP	RPM	BHP	RPM	BHP	RPM	BHP	RPM	BHP	RPM	BHP	RPM	BHP	RPM	BHP	RPM	BHP
15884	1206	10.32																
17328	1238	11.18	1320	13.52														
18772	1275	12.10	1351	14.55	1427	17.08												
20216	1316	13.12	1387	15.63	1457	18.29	1528	21.01										
21660	1360	14.26	1428	16.83	1494	19.55	1559	22.38	1625	25.30								
23104	1405	15.52	1470	18.14	1534	20.91	1596	23.83	1657	26.86	1718	29.95	1781	33.08				
24548	1453	16.93	1515	19.59	1576	22.41	1636	25.38	1694	28.48	1751	31.69	1809	34.97	1867	38.29		
25992	1503	18.47	1562	21.18	1620	24.05	1677	27.08	1733	30.23	1788	33.50	1843	36.89	1897	40.35	1952	43.86
27436	1554	20.15	1610	22.93	1666	25.85	1721	28.91	1775	32.12	1828	35.46	1880	38.91	1932	42.46	1984	46.10
28880	1608	22.00	1661	24.84	1714	27.81	1767	30.92	1819	34.17	1870	37.56	1920	41.06	1970	44.69	2019	48.41
30324	1662	23.98	1712	26.89	1763	29.93	1814	33.09	1864	36.40	1914	39.83	1962	43.38	2010	47.06		
31768	1718	26.13	1766	29.12	1814	32.22	1862	35.45	1911	38.81	1958	42.28	2006	45.88				
33212	1775	28.44	1820	31.51	1867	34.69	1913	37.98	1959	41.39	2005	44.92						
34656	1832	30.92	1876	34.08	1920	37.34	1964	40.69	2009	44.17								
36100	1891	33.57	1933	36.82	1975	40.17	2017	43.59										

- Notes:
- 1) Performance shown is for Installation Type D: ducted inlet, ducted outlet.
 - 2) Performance ratings do not include the effects of appurtenances in the airstream.
 - 3) Power rating (BHP) does not include drive losses.

VXB - Belt Drive Fan Data

Vaneaxial Fan

042

Wheel Diameter = 42 in.	Maximum RPM = 1620
Tip Speed, FPM = 11.00 x RPM	Bare Fan Weight = 1050 lbs.
Inlet & Outlet Diameter (Area) = 42.44 in. (9.82 sq.ft.)	

CFM	0" SP		1/4" SP		1/2" SP		3/4" SP		1" SP		1 1/4" SP		1 1/2" SP	
	RPM	BHP	RPM	BHP	RPM	BHP	RPM	BHP	RPM	BHP	RPM	BHP	RPM	BHP
11784	344	0.35	421	0.87	495	1.52	566	2.30						
13748	402	0.56	467	1.14	532	1.84	594	2.66	655	3.57				
15712	459	0.83	517	1.49	574	2.23	630	3.09	684	4.05	736	5.10		
17676	517	1.19	569	1.91	618	2.71	669	3.61	719	4.61	766	5.70	813	6.86
19640	574	1.63	621	2.43	666	3.29	711	4.23	757	5.27	801	6.39	844	7.61
21604	631	2.17	675	3.04	715	3.97	756	4.97	798	6.04	839	7.20	879	8.44
23568	689	2.81	729	3.76	766	4.76	804	5.81	842	6.94	880	8.14	917	9.41
25532	746	3.58	784	4.60	818	5.67	853	6.79	887	7.96	922	9.21	957	10.52
27496	804	4.47	839	5.56	871	6.70	903	7.89	935	9.13	967	10.42	1000	11.78
29460	861	5.50	894	6.66	924	7.88	954	9.13	984	10.43	1014	11.78	1044	13.19
31424	918	6.67	949	7.91	978	9.19	1006	10.52	1034	11.89	1062	13.30	1090	14.76
33388	976	8.00	1005	9.32	1032	10.67	1059	12.07	1085	13.50	1111	14.98	1138	16.50
35352	1033	9.50	1061	10.89	1087	12.32	1112	13.79	1137	15.29	1162	16.83	1187	18.40
37316	1091	11.17	1117	12.63	1142	14.14	1166	15.68	1189	17.25	1213	18.86	1236	20.50
39380	1148	13.03	1173	14.57	1197	16.14	1220	17.75	1242	19.40	1265	21.08	1287	22.78
41244	1205	15.08	1230	16.70	1252	18.35	1274	20.03	1296	21.75	1317	23.49	1338	25.27
43280	1263	17.34	1286	19.03	1308	20.75	1329	22.53	1350	24.30	1370	26.12	1390	27.96
45172	1320	19.81	1342	21.58	1363	23.38	1384	25.21	1404	27.07	1423	28.95	1443	30.87
47136	1378	22.51	1399	24.36	1419	26.23	1439	28.13	1458	30.06	1477	32.01	1495	34.01
49100	1435	25.45	1455	27.36	1475	29.32	1494	31.28	1512	33.29	1530	35.31	1549	37.37

CFM	2" SP		2 1/2" SP		3" SP		3 1/2" SP		4" SP		4 1/2" SP		5" SP		5 1/2" SP	
	RPM	BHP	RPM	BHP	RPM	BHP	RPM	BHP	RPM	BHP	RPM	BHP	RPM	BHP	RPM	BHP
19640	928	10.20														
21604	957	11.15	1033	14.05												
23568	990	12.19	1060	15.22	1131	18.40										
25532	1026	13.37	1093	16.48	1157	19.80	1223	23.25								
27496	1065	14.69	1128	17.87	1189	21.28	1249	24.89	1309	28.58						
29460	1105	16.18	1165	19.43	1223	22.91	1280	26.61	1336	30.47	1392	34.43				
31424	1147	17.84	1204	21.16	1260	24.70	1314	28.47	1367	32.43	1420	36.55	1472	40.77	1526	45.03
33388	1191	19.68	1245	23.07	1298	26.69	1350	30.52	1401	34.56	1451	38.77	1501	43.12	1550	47.60
35352	1237	21.70	1288	25.18	1338	28.86	1388	32.77	1437	36.86	1485	41.16	1532	45.61		
37316	1284	23.90	1332	27.49	1380	31.25	1428	35.22	1475	39.38	1521	43.74	1566	48.27		
39280	1332	26.31	1377	29.99	1423	33.85	1468	37.89	1514	42.14	1558	46.54				
41244	1381	28.92	1424	32.72	1467	36.67	1511	40.80	1554	45.10						
43280	1431	31.74	1472	35.66	1513	39.72	1554	43.94	1596	48.31						
45172	1481	34.79	1520	38.82	1559	42.99	1599	47.32								
47136	1532	38.05	1570	42.22	1607	46.51										
49100	1584	41.56	1620	45.86												

- Notes:**
- 1) Performance shown is for Installation Type D: ducted inlet, ducted outlet.
 - 2) Performance ratings do not include the effects of appurtenances in the airstream.
 - 3) Power rating (BHP) does not include drive losses.

Belt Drive Fan Data - VXB

Vaneaxial Fan

048

Wheel Diameter = 48 in.	Maximum RPM = 1576
Tip Speed, FPM = 12.57 x RPM	Bare Fan Weight = 1400 lbs.
Inlet & Outlet Diameter (Area) = 48.50 in. (12.83 sq.ft.)	

CFM	0" SP		1/4" SP		1/2" SP		3/4" SP		1" SP		1 1/4" SP		1 1/2" SP		2" SP		2 1/2" SP	
	RPM	BHP	RPM	BHP	RPM	BHP	RPM	BHP	RPM	BHP	RPM	BHP	RPM	BHP	RPM	BHP	RPM	BHP
15396	301	0.46	368	1.13	433	1.99	495	3.00										
17962	352	0.73	409	1.49	466	2.40	520	3.48	573	4.67								
20528	402	1.09	452	1.94	502	2.91	551	4.03	598	5.30	644	6.66						
23094	452	1.55	498	2.50	541	3.54	586	4.71	629	6.02	670	7.45	711	8.97				
25660	502	2.13	544	3.17	583	4.30	623	5.53	662	6.88	701	8.35	739	9.94	812	13.33		
28226	553	2.83	591	3.97	626	5.19	662	6.49	698	7.89	734	9.41	769	11.03	837	14.57	904	18.36
30792	603	3.68	638	4.91	671	6.22	703	7.60	736	9.07	770	10.63	803	12.30	867	15.93	928	19.89
33358	653	4.68	686	6.01	716	7.40	746	8.87	777	10.41	807	12.03	838	13.75	898	17.47	956	21.53
35924	703	5.84	734	7.27	762	8.76	790	10.31	818	11.92	846	13.62	875	15.39	932	19.20	987	23.35
38490	754	7.18	782	8.71	809	10.29	835	11.93	861	13.63	887	15.40	914	17.24	967	21.14	1020	25.38
41056	804	8.72	831	10.34	856	12.02	881	13.75	905	15.53	930	17.38	954	19.29	1004	23.32	1054	27.64
43622	854	10.46	880	12.18	904	13.95	927	15.78	950	17.65	973	19.57	996	21.56	1043	25.71	1090	30.15
46188	904	12.41	929	14.23	951	16.10	973	18.02	995	19.98	1017	21.99	1039	24.06	1082	28.35	1127	32.90
48754	954	14.60	978	16.52	999	18.48	1020	20.49	1041	22.54	1061	24.65	1082	26.79	1124	31.24	1165	35.91
51320	1005	17.03	1027	19.04	1048	21.10	1068	23.21	1087	25.36	1107	27.54	1126	29.78	1166	34.39	1205	39.20
53886	1055	19.71	1076	21.82	1096	23.98	1115	26.19	1134	28.42	1153	30.70	1171	33.02	1209	37.79	1246	42.76
56452	1105	22.67	1125	24.87	1145	27.13	1163	29.42	1181	31.75	1199	34.13	1217	36.54	1252	41.49	1288	46.60
59018	1155	25.90	1175	28.21	1193	30.56	1211	32.95	1228	35.38	1246	37.84	1262	40.34	1296	45.45	1331	50.74
61584	1206	29.43	1224	31.83	1242	34.28	1259	36.76	1276	39.29	1292	41.85	1309	44.43	1341	49.73	1374	55.17
64150	1256	33.26	1274	35.76	1291	38.31	1308	40.89	1324	43.51	1340	46.16	1355	48.84	1387	54.31	1418	59.92

CFM	3" SP		3 1/2" SP		4" SP		4 1/2" SP		5" SP		5 1/2" SP		6" SP		6 1/2" SP		7" SP	
	RPM	BHP	RPM	BHP	RPM	BHP	RPM	BHP	RPM	BHP	RPM	BHP	RPM	BHP	RPM	BHP	RPM	BHP
30792	990	24.03																
33358	1013	25.87	1070	30.37														
35924	1040	27.82	1093	32.51	1146	37.35												
38490	1071	29.94	1120	34.77	1169	39.81	1218	44.98										
41056	1103	32.28	1150	37.20	1197	42.38	1242	47.76	1289	53.27	1336	58.83						
43622	1136	34.87	1182	39.88	1226	45.15	1270	50.66	1313	56.35	1356	62.19	1400	68.09				
46188	1171	37.72	1215	42.82	1258	48.17	1300	53.78	1341	59.59	1382	65.60	1423	71.75	1464	77.98	1506	84.25
48754	1207	40.84	1249	46.02	1291	51.46	1331	57.16	1371	63.07	1410	69.22	1449	75.53	1487	81.97	1526	88.53
51320	1245	44.23	1285	49.51	1325	55.05	1364	60.82	1402	66.84	1440	73.08	1477	79.51	1514	86.09	1551	92.85
53886	1284	47.92	1322	53.31	1360	58.93	1398	64.79	1435	70.89	1471	77.21	1507	83.74	1543	90.47		
56452	1324	51.90	1360	57.42	1396	63.13	1433	69.08	1469	75.27	1504	81.66	1539	88.27	1573	95.10		
59018	1365	56.19	1399	61.83	1434	67.66	1469	73.71	1503	79.97	1538	86.48	1572	93.16				
61584	1407	60.78	1440	66.56	1473	72.53	1506	78.69	1539	85.06	1572	91.62						
64150	1449	65.68	1481	71.61	1513	77.71	1544	83.99	1576	90.46								

- Notes:**
- 1) Performance shown is for Installation Type D: ducted inlet, ducted outlet.
 - 2) Performance ratings do not include the effects of appurtenances in the airstream.
 - 3) Power rating (BHP) does not include drive losses.

VXB - Belt Drive Fan Data

Vaneaxial Fan

054

Wheel Diameter = 54 in.	Maximum RPM = 1316
Tip Speed, FPM = 14.14 x RPM	Bare Fan Weight = 2100 lbs.
Inlet & Outlet Diameter (Area) = 54.56 in. (16.24 sq.ft.)	

CFM	0" SP		1/4" SP		1/2" SP		3/4" SP		1" SP		1 1/4" SP		1 1/2" SP		2" SP	
	RPM	BHP	RPM	BHP	RPM	BHP	RPM	BHP	RPM	BHP	RPM	BHP	RPM	BHP	RPM	BHP
19488	268	0.58	327	1.43	385	2.52	440	3.80								
22836	313	0.92	364	1.89	414	3.04	462	4.40	509	5.91						
25984	357	1.38	402	2.46	446	3.69	490	5.11	532	6.70	573	8.43				
29232	402	1.96	442	3.16	481	4.49	521	5.97	559	7.62	596	9.43	632	11.35		
32480	447	2.70	483	4.01	518	5.44	553	7.00	589	8.71	623	10.58	657	12.58	722	16.87
35728	491	3.59	525	5.03	557	6.56	588	8.21	621	9.99	653	11.91	684	13.97	744	18.44
38976	536	4.66	567	6.22	596	7.87	625	9.62	655	11.47	684	13.46	714	15.57	770	21.17
42224	581	5.92	610	7.60	637	9.37	663	11.23	690	13.17	718	15.23	745	17.40	798	22.11
45472	625	7.40	652	9.20	678	11.09	702	13.05	727	15.10	753	17.24	778	19.48	828	24.30
48720	670	9.10	695	11.02	719	13.03	742	15.11	766	17.26	789	19.49	812	21.82	860	26.77
51968	715	11.04	739	13.09	761	15.22	783	17.41	805	19.67	826	22.00	848	24.42	893	29.51
55216	759	13.24	782	15.42	803	17.66	824	19.97	844	22.34	865	24.78	885	27.29	927	32.55
58464	804	15.72	826	18.02	846	20.38	865	22.81	885	25.29	904	27.84	923	30.45	962	35.90
61712	849	18.49	869	20.91	888	23.40	907	25.94	925	28.54	944	31.20	962	33.92	999	39.55
64960	893	21.56	913	24.11	931	26.72	949	29.38	967	32.10	984	34.87	1001	37.70	1036	43.53
68208	938	24.96	957	27.63	974	30.36	991	33.15	1008	35.99	1025	38.87	1041	41.80	1074	47.85
71456	983	28.70	1001	31.49	1018	34.35	1034	37.26	1050	40.21	1066	43.20	1082	46.26	1113	52.51
74704	1027	32.79	1044	35.71	1061	38.69	1077	41.72	1092	44.79	1107	47.90	1122	51.07	1153	57.55
77952	1072	37.26	1088	40.30	1104	43.40	1119	46.58	1134	49.74	1149	52.97	1163	56.26	1192	62.95
81200	1117	42.11	1132	45.28	1148	48.51	1162	51.77	1177	55.09	1191	58.43	1205	61.83	1233	68.77

CFM	2 1/2" SP		3" SP		3 1/2" SP		4" SP		4 1/2" SP		5" SP		5 1/2" SP		6" SP	
	RPM	BHP	RPM	BHP	RPM	BHP	RPM	BHP	RPM	BHP	RPM	BHP	RPM	BHP	RPM	BHP
35728	804	23.23														
38976	825	25.18	880	30.42												
42224	850	27.26	900	32.75	951	38.44										
45472	877	29.56	925	35.21	971	41.15	1018	47.28								
48720	906	32.13	952	37.90	996	44.01	1039	50.39	1083	56.94						
51968	937	34.99	980	40.86	1022	47.09	1064	53.64	1104	60.44	1145	67.42	1187	74.47		
55216	969	38.16	1010	44.14	1051	50.48	1090	57.16	1129	64.12	1167	71.33	1206	78.70	1245	86.19
58464	1002	41.65	1041	47.75	1080	54.19	1118	60.98	1155	68.07	1192	75.45	1228	83.03	1265	90.81
61712	1036	45.46	1073	51.69	1111	58.26	1147	65.14	1183	72.35	1219	79.83	1253	87.61	1288	95.60
64960	1071	49.62	1107	56.01	1142	62.68	1178	69.67	1212	76.99	1247	84.60	1280	92.48		
68208	1108	54.13	1141	60.67	1175	67.48	1209	74.61	1242	82.02	1276	89.74				
71456	1145	58.99	1177	65.71	1209	72.68	1241	79.93	1274	87.45	1305	95.27				
74704	1183	64.23	1213	71.13	1244	78.27	1275	85.65	1306	93.31						
77952	1221	69.84	1250	76.94	1280	84.25	1309	91.79								
81200	1260	75.86	1288	83.16	1316	90.66										

- Notes:
- 1) Performance shown is for Installation Type D: ducted inlet, ducted outlet.
 - 2) Performance ratings do not include the effects of appurtenances in the airstream.
 - 3) Power rating (BHP) does not include drive losses.

Belt Drive Fan Data - VXB

Vaneaxial Fan

060

Wheel Diameter = 60 in.	Maximum RPM = 1134
Tip Speed, FPM = 15.71 x RPM	Bare Fan Weight = 2500 lbs.
Inlet & Outlet Diameter (Area) = 60.63 in. (20.05 sq.ft.)	

CFM	0" SP		1/4" SP		1/2" SP		3/4" SP		1" SP		1 1/4" SP		1 1/2" SP	
	RPM	BHP	RPM	BHP	RPM	BHP	RPM	BHP	RPM	BHP	RPM	BHP	RPM	BHP
24060	241	0.72	295	1.77	347	3.11	396	4.69						
28070	281	1.14	327	2.33	373	3.75	416	5.43	458	7.29				
32080	322	1.70	362	3.04	402	4.56	441	6.31	479	8.28	515	10.40		
36090	362	2.43	398	3.90	433	5.54	468	7.37	503	9.41	536	11.64	569	14.02
40100	402	3.33	435	4.95	466	6.72	498	8.65	530	10.75	561	13.06	591	15.52
44110	442	4.43	473	6.21	501	8.10	530	10.14	559	12.34	588	14.71	616	17.25
48120	482	5.75	510	7.67	537	9.72	563	11.87	589	14.17	616	16.62	642	19.22
52130	523	7.31	549	9.39	573	11.57	597	13.86	621	16.26	646	18.81	670	21.49
56140	563	9.13	587	11.36	610	13.69	632	16.12	655	18.64	677	21.28	700	24.04
60150	603	11.23	626	13.62	647	16.09	668	18.65	689	21.31	710	24.06	731	26.94
64160	643	13.63	665	16.17	685	18.79	705	21.49	724	24.29	744	27.16	764	30.15
68170	683	16.35	704	19.05	723	21.82	742	24.65	760	27.59	778	30.60	797	33.69
72180	724	19.41	743	22.25	761	25.18	779	28.18	796	31.22	814	34.39	831	37.59
76190	764	22.83	782	25.82	800	28.90	816	32.03	833	35.23	849	38.51	866	41.87
80200	804	26.63	822	29.77	838	33.01	854	36.28	870	39.64	886	43.04	901	46.53
84210	844	30.83	861	34.13	877	37.49	892	40.92	907	44.42	922	48.01	937	51.64
88220	84	35.44	900	38.88	916	42.43	931	46.02	945	49.67	959	53.35	973	57.12
92230	925	40.50	940	44.10	955	47.77	969	51.51	983	55.30	997	59.15	1010	63.07
96240	965	46.02	980	49.74	994	53.59	1007	57.46	1021	61.40	1034	65.43	1047	69.44
100250	1005	52.01	1019	55.93	1033	59.87	1046	63.92	1059	68.03	1072	72.17	1084	76.35

CFM	2" SP		2 1/2" SP		3" SP		3 1/2" SP		4" SP		4 1/2" SP		5" SP		5 1/2" SP	
	RPM	BHP	RPM	BHP	RPM	BHP	RPM	BHP	RPM	BHP	RPM	BHP	RPM	BHP	RPM	BHP
40100	650	20.83														
44110	670	22.76	724	28.68												
48120	693	24.90	742	31.09	792	37.55										
52130	719	27.30	765	33.64	810	40.44	856	47.44								
56140	745	30.00	790	36.50	932	43.45	874	50.80	917	58.35						
60150	774	33.05	816	39.66	856	46.77	896	54.33	935	62.18	975	70.29				
64160	803	36.44	843	43.22	882	50.45	920	58.12	957	66.22	994	74.61	1031	83.22	1069	91.93
68170	834	40.18	872	47.13	909	54.49	946	62.33	981	70.58	1016	79.16	1051	88.05	1085	97.16
72180	866	44.32	902	51.43	937	58.93	972	66.91	1006	75.28	1040	84.02	1073	93.16		
76190	899	48.83	932	56.14	966	63.82	1000	71.92	1033	80.44	1065	89.33	1097	98.54		
80200	933	53.74	964	61.25	996	69.17	1028	77.39	1060	86.04	1091	95.04				
84210	967	59.08	997	66.81	1027	74.92	1058	83.32	1088	92.08						
88220	1002	64.82	1030	72.81	1059	81.15	1088	89.70	1117	98.72						
92230	1037	71.05	1065	79.32	1092	87.78	1120	96.63								
96240	1073	77.73	1099	86.27	1125	94.97										
100250	1109	84.91	1134	93.66												

- Notes:**
- 1) Performance shown is for Installation Type D: ducted inlet, ducted outlet.
 - 2) Performance ratings do not include the effects of appurtenances in the airstream.
 - 3) Power rating (BHP) does not include drive losses.

Sample Specifications

VXD/VXB - Vaneaxial Fan

- 1.1 Fans shall be tested and rated in accordance with AMCA methods and standards.
- 1.2 The fans shall be licensed to bear the AMCA Seal for air. The ratings shown in the product catalog must be based on tests and procedures performed in accordance with AMCA publication 211 and shall comply with the requirements of the AMCA Certified Ratings Program.
- 1.3 Fans shall conform to AMCA 99 Standards.
- 1.4 All motors and electrical components shall comply to NEMA, UL and CSA guidelines.

Direct Drive Vaneaxial

- 2.1 The fan shall be of an axial flow vaneaxial type configuration with a bolt-on straightening vane section.
- 2.2 The fan shall be direct drive with the propeller mounted on the motor shaft by means of a taper lock bushing.
- 2.3 The fan casing shall be of all welded construction with a flanged inlet and outlet, and shall be constructed completely of carbon steel, stainless steel (type 316 or 304) or aluminum as indicated on fan schedule.
- 2.4 A bolt-on straightening vane section shall be mounted on the discharge end of the fan housing.
- 2.5 The propeller shall be constructed of 319F cast aluminum material with the cast blades welded to the cast hub per AWS welding standards. The hub is designed to incorporate a taper lock bushing and keyed to the motor shaft.
- 2.6 The fan shall be coated with enamel as standard or optional other available coating as made available by coating suppliers and as indicated on the fan schedule.
- 3.0 The motor shall be of a typical NEMA-T frame type and standard in nature with the motor industry availability. The electric motor shall be as indicated on the fan schedule and is available in any enclosure as made available from the motor vendors.
- 3.1 The motor leads shall be extended through the fan casing for accessibility.
- 3.2 The fan shall be factory dynamically balanced at operating speed per AMCA 204 Grade BV-3/ ANSI S2.19 G 6.3 and the results recorded on a label placed on the fan assembly.
- 4.0 Fan shall be cUL listed for UL705.

Belt Drive Vaneaxial

- 2.1 The fan shall be of an axial flow vaneaxial type configuration with a bolt-on straightening vane section.
- 2.2 The fan shall be belt drive, sized for 1.5 service factor. Motor is mounted externally on the fan casing and not exposed to the air stream.
- 2.3 The fan casing shall be of all welded construction with a flanged inlet and outlet, and shall be constructed completely of carbon steel, stainless steel (type 316 or 304) or aluminum as indicated on fan schedule.
 - 2.3.1 The fan shall have an inner tube section, fully welded protecting the shaft, bearings and drive components from direct air stream exposure.
 - 2.3.2 The inner tube assembly shall have removable end covers to allow for access to the bearing and drive assembly.
- 2.4 The fan shaft shall be steel, ground for precision fit to bearings and keyed for driving the impeller and drive sheave.
- 2.5 Fan bearings shall be cast iron housing, self-aligning, re-lubricatable bearings with grease lines extended to the exterior of the casing. A.F.B.M.A. Bearing L_{10} life of 40,000 hours.
- 2.6 The propeller shall be constructed of 319F cast aluminum material with the cast blades welded to the cast hub per AWS welding standards. The hub is designed to incorporate a taper lock bushing and keyed to the fan shaft.
- 2.7 The motor mounting base is configured to allow for various frame sizes and designed to allow for belt tensioning.
- 2.8 The fan shall be coated with enamel as standard or optional other available coating as made available by coating suppliers and as indicated on the fan schedule.
- 2.9 The fan shall be of AMCA spark resistant construction when required and as indicated on the fan schedule as AMCA "A", "B" or "C" as defined by AMCA Standard 99.
- 3.0 The motor shall be of a typical NEMA-T frame type and standard in nature with the motor industry availability. The electric motor shall be as indicated on the fan schedule.
 - 3.1 The fan shall be factory dynamically balanced at operating speed per AMCA 204 Grade BV-3/ ANSI S2.19 G 6.3 and the results recorded on a label placed on the fan assembly.

OTHER PENNBARRY PRODUCTS

CENTRIFUGAL PRODUCTS



Domex
Centrifugal
Roof Exhausters



Fumex Fatrap
Kitchen Hood Centrifugal
Roof Exhausters



Zephyr
Ceiling and Inline Fans

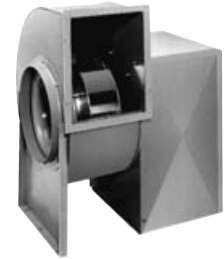

Dynamo
Centrifugal Blowers



Centrex Inliner
Centrifugal Inline Fans



LC Dynafan
Low Contour Centrifugal
Roof Exhausters



ESI
Efficient Silent
Inline Fan



Fume Exhaust
Curb Mounted
Centrifugal Fans

AXIAL / GRAVITY PRODUCTS

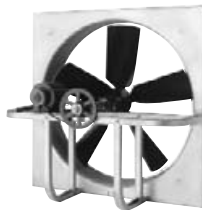

Breezeway
Propeller Wall Fans



HI-EX
Power Roof Ventilator



Tubeaxial
Inline Fans



Vaneaxial
Inline Fans



Powered Airette
Axial Roof Ventilators



Airette
Gravity Intake/Relief Hood



Domex Axial
Axial Roof Ventilators



Axcentrix
Bifurcator Fan

For more information contact your local PennBarry Sales
Manufacturer Representative or visit us at www.PennBarry.com

